

Commercial Frontload Washer SWF 3

Parts

Refer to Page 3 for Model Numbers

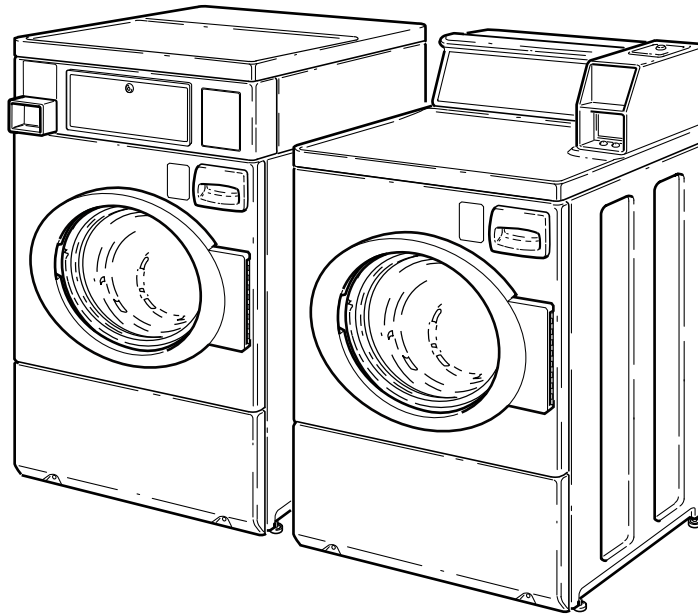

FLW1535C_802739

Parts Ordering Information

If literature or replacement parts are required, contact the source from whom the machine was purchased or contact Alliance Laundry Systems at for the name and address of the nearest authorized parts distributor.

Nameplate Location

When calling or writing about your product, be sure to mention model and serial numbers. Model and serial numbers are located on nameplate(s) as shown.

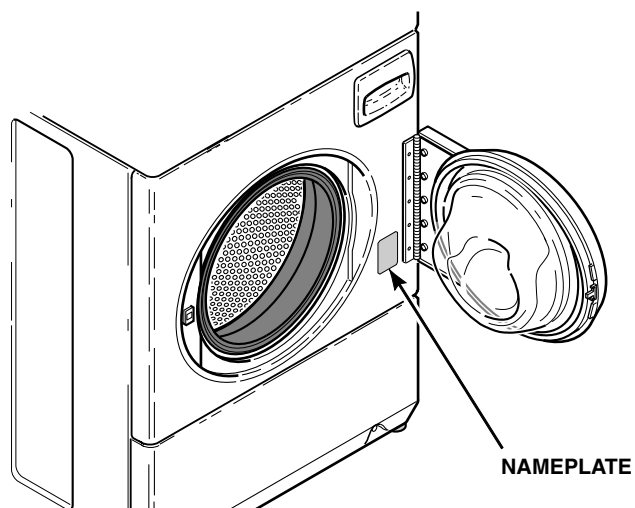

FLW2123N_802739

Model Identification

Information in this manual is applicable to these washer models:

BFNBCFSG111TN01	HWFB71*N	SFNCCFSP111TW01
BFNBCFSG111TW01	HWFB71*N1102	SFNCCRSP111TW01
BFNBCFSG112TN01	HWFR71*N1102	SFNCCRSP111TW02
BFNBCFSG112TW01	HWFT71*N	SFNCXRSP111TW02
BFNBEFSP111CN01	HWFT71*N1102	SFNCFYFSP111TW01
BFNBEFSP111CW01	HWFT73*N	SFNCFYRSP111TW01
BFNBEFSP111TN01	HWFT73*N1102	SFNSXRSP111TW02
BFNBEFSP111TW01	HWFX71*N1102	SFNSXRSP112TQ01
BFNBEFSP112CN01	HWFX71*N1127	SFNSXRSP112TW01
BFNBEFSP112CW01	HWFY71*N1102	SFNSXRSP112TW02
BFNBLFSP301AW01	HWFY73*N1102	SFNSXRSP541NQ23
BFNBLFSP302AW01	HWFY74*N4000	SFNSXRSP541NW23
BFNBLFSP541NW01	HWFY75*N4000	SFNTXRSP111TW01
BFNBLFSP542NW01	HWR971*N1102	SFNTXRSP111TW02
BFNBXFSP112FW01	HWR971*N1127	SWFA71*N
BFNBXFSP302AW01	HWR973*N1102	SWFA71*N3050
BFNBYFSP112TW01	HWRR71*N1102	SWFA71*N3069
BWFL74*N4000	HWRT71*N	SWFA73*N
BWFL75*N4000	HWRT71*N1102	SWFB71*N
BWFX71*N1127	HWRX71*N1102	SWFB72*N
BWFX71*N3050	HWRY71*N1102	SWFB73*N
BWFX74*N4000	NWFL84*N4000	SWFF71*N
BWFX75*N4000	NWFL85*N4000	SWFF71*N3050
HFNBCFSG111TN01	NWFX74*N4000	SWFF73*N
HFNBCFSG112TN01	NWFX75*N4000	SWFL74*N4000
HFNBCFSG112TQ01	SFNBCFSG112TQ01	SWFT71*N
HFNBCFSG112TW01	SFNBCFSG112TW01	SWFT73*N
HFNBCFSP111TN01	SFNBCFSP112TQ01	SWFX71*N
HFNBCFSP112TN01	SFNBCFSP112TW01	SWFX71*N1127
HFNBCFSP112TQ01	SFNBCRSP111TW02	SWFX71*N3000
HFNBCFSP112TW01	SFNBCRSP112TW01	SWFX71*N3050
HFNBCRSP112TW01	SFNBCRSP112TW02	SWFX71*N3051
HFNBDFSG112CW01	SFNBXFSG082JW01	SWFX71*N5400
HFNBDFSP112CW01	SFNBXFSG112TQ01	SWFX73*N
HFNBDRSP112CW01	SFNBXFSG112TW01	SWFX74*N4000
HFNBEFSP112CW01	SFNBXFSP112TQ01	SWFX75*N4000
HFNBERSP112CW01	SFNBXFSP112TW01	SWFY71*N
HFNBXFSP112CW01	SFNBXFSP122DW01	SWFY73*N
HFNBXFSP112FQ01	SFNBXFSP301NW22	SWR971*N
HFNBXFSP122DW01	SFNBXFSP302AW01	SWR973*N
HFNBXFSP302NW22	SFNBXFSP302NQ01	SWRB71*N
HFNBXFSP542DW01	SFNBXFSP302NW01	SWRF71*N
HFNBXRSP112FW28	SFNBXFSP302NW22	SWRT71*N
HFNBXFSG112CW01	SFNBXFSP542DW01	SWRT73*N
HFNBXFSP112CW01	SFNBXRSP112TW01	SWRX71*N
HFNBXRSP112CW01	SFNBXRSP112TW02	SWRY71*N
HFNCXFSP111CW01	SFNBYFSG112TW01	
HFNCXRSP111CW01	SFNBYFSP112TW01	
HFNSXRSP112CW01	SFNBYRSP112TW01	

SWF 3

Control Panel and Controls (Drawing 1 of 2)

Models BFNBCFSG111TN01, BFNBCFSG111TW01, BFNBEFSP111CN01, BFNBEFSP111CW01, BFNBEFSP111TN01, BFNBEFSP111TW01, BWFX71*N1127, BWFX71*N3050, BWFX74*N4000, BWFX75*N4000, HFNBCFSG111TN01, HFNBCFSP111TN01, HFNCXFSP111CW01, HWFB71*N, HWFB71*N1102, HWFR71*N1102, HWFT71*N, HWFT71*N1102, HWFT73*N, HWFT73*N1102, HWFX71*N1102, HWFX71*N1127, HWFY71*N1102, HWFY73*N1102, HWFY74*N4000, HWFY75*N4000, NWF74*N4000, NWF75*N4000, SFNBXFSP301NW22, SFNCCFSP111TW01, SFNCYFSP111TW01, SWFA71*N, SWFA71*N3050, SWFA71*N3069, SWFA73*N, SWFB71*N, SWFB72*N, SWFB73*N, SWFF71*N, SWFF71*N3050, SWFF73*N, SWFT71*N, SWFT73*N, SWFX71*N, SWFX71*N1127, SWFX71*N3000, SWFX71*N3050, SWFX71*N3051, SWFX71*N5400, SWFX73*N, SWFX74*N4000, SWFX75*N4000, SWFY71*N and SWFY73*N

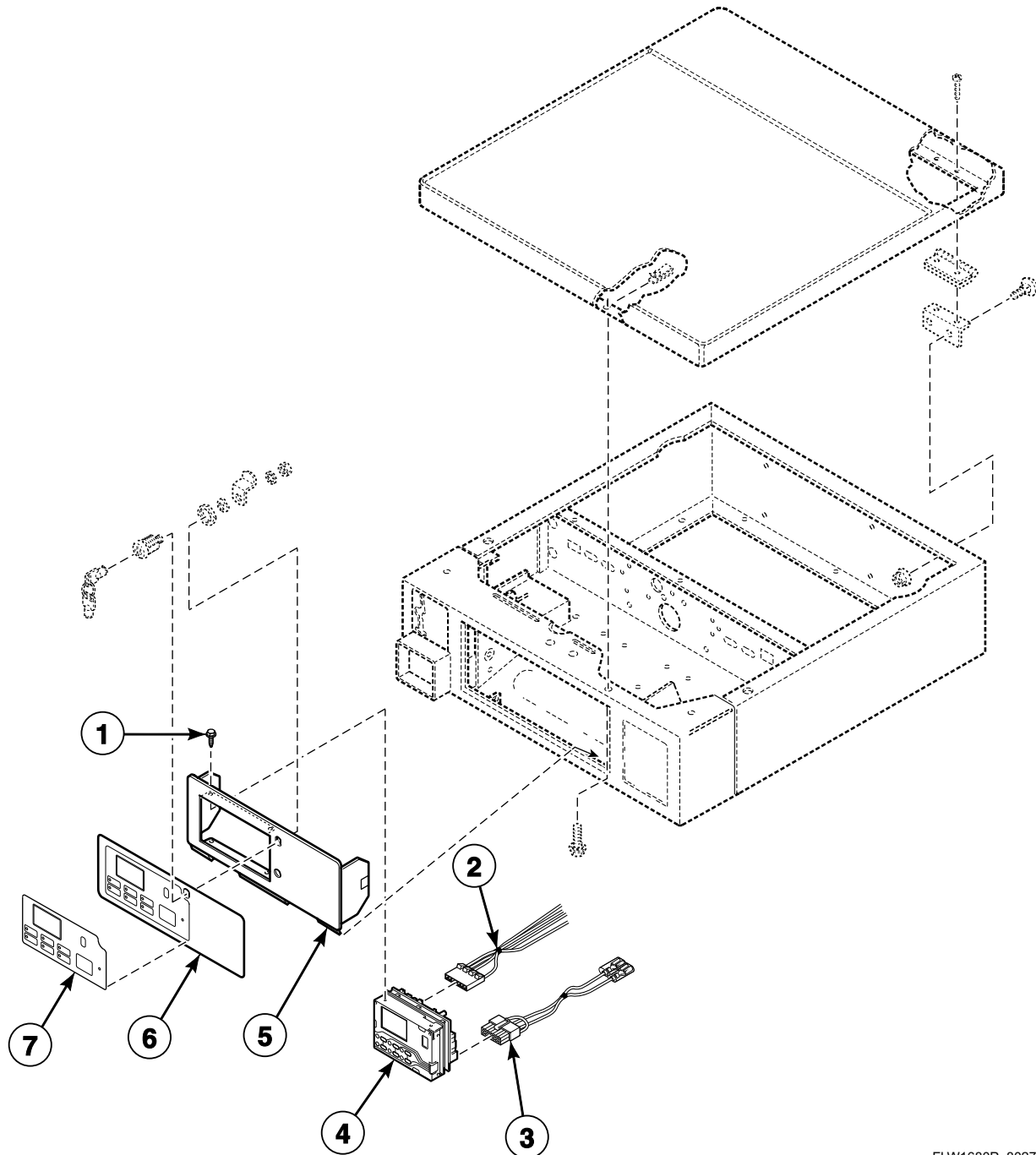

FLW1680P_802739

SWF 3 P1

© Copyright, Alliance Laundry Systems LLC – DO NOT COPY or TRANSMIT

Control Panel and Controls (Drawing 2 of 2)

Models BFNBCFSG112TN01, BFNBCFSG112TW01, BFNBESP112CN01, BFNBESP112CW01, BFNBXFSP112FW01, BFNBXFSP302AW01, BFNBXFSP112TW01, HFNBCFSG112TN01, HFNBCFSG112TQ01, HFNBCFSG112TW01, HFNBCFSP112TN01, HFNBCFSP112TQ01, HFNBCFSP112TW01, HFNBDFSG112CW01, HFNBDFSP112CW01, HFNBESP112CW01, HFNBXFSP112CW01, HFNBXFSP112FQ01, HFNBXFSP122DW01, HFNBXFSP302NW22, HFNBXFSP542DW01, HFNBXFSG112CW01, HFNBXFSP112CW01, SFNBCFSG112TQ01, SFNBCFSG112TW01, SFNBXFSP112TQ01, SFNBXFSP112TW01, SFNBXFSG082JW01, SFNBXFSG112TQ01, SFNBXFSG112TW01, SFNBXFSP112TQ01, SFNBXFSP112TW01, SFNBXFSP122DW01, SFNBXFSP302AW01, SFNBXFSP302NQ01, SFNBXFSP302NW01, SFNBXFSP302NW22, SFNBXFSP542DW01, SFNBXFSG112TW01 and SFNBXFSP112TW01

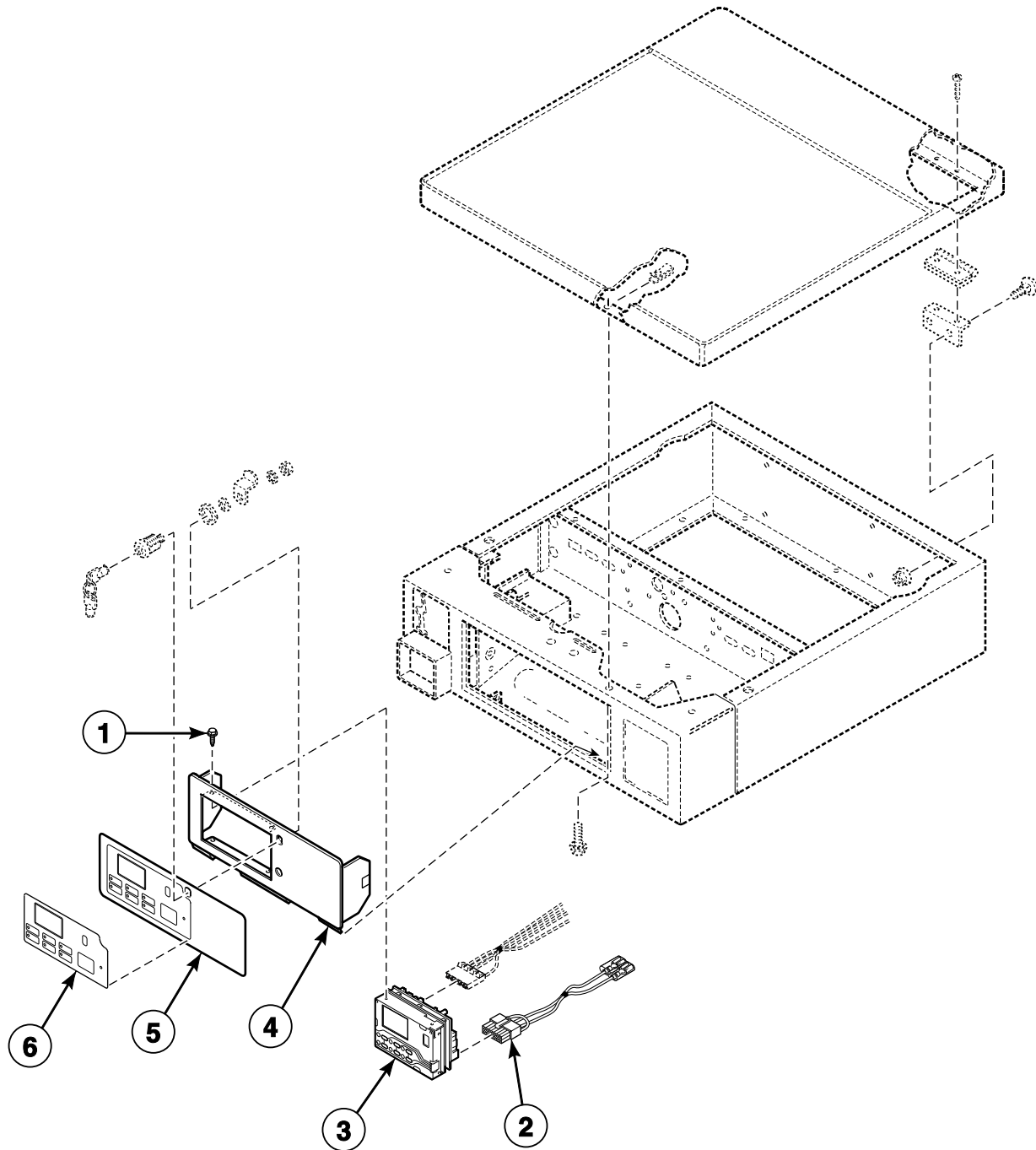

FLW1680PA_802739

SWF 3 P2

© Copyright, Alliance Laundry Systems LLC – DO NOT COPY or TRANSMIT

Top Assembly (Drawing 1 of 2)

Models BFNBCFSG111TN01, BFNBCFSG111TW01, BFNBEFSP111CN01, BFNBEFSP111CW01, BFNBEFSP111TN01, BFNBEFSP111TW01, BWF71*N1127, BWF71*N3050, BWF74*N4000, BWF75*N4000, HFNBCFSG111TN01, HFNBCFSP111TN01, HFNCXFSP111CW01, HWFB71*N, HWFB71*N1102, HWFR71*N1102, HWFT71*N, HWFT71*N1102, HWFT73*N, HWFT73*N1102, HWFX71*N1102, HWFX71*N1127, HWFY71*N1102, HWFY73*N1102, HWFY74*N4000, HWFY75*N4000, NWF74*N4000, NWF75*N4000, SFNBXFSP301NW22, SFNCCFSP111TW01, SFNCYFSP111TW01, SWFA71*N, SWFA71*N3050, SWFA71*N3069, SWFA73*N, SWFB71*N, SWFB72*N, SWFB73*N, SWFF71*N, SWFF71*N3050, SWFF73*N, SWFT71*N, SWFT73*N, SWFX71*N, SWFX71*N1127, SWFX71*N3000, SWFX71*N3050, SWFX71*N3051, SWFX71*N5400, SWFX73*N, SWFX74*N4000, SWFX75*N4000, SWFY71*N and SWFY73*N

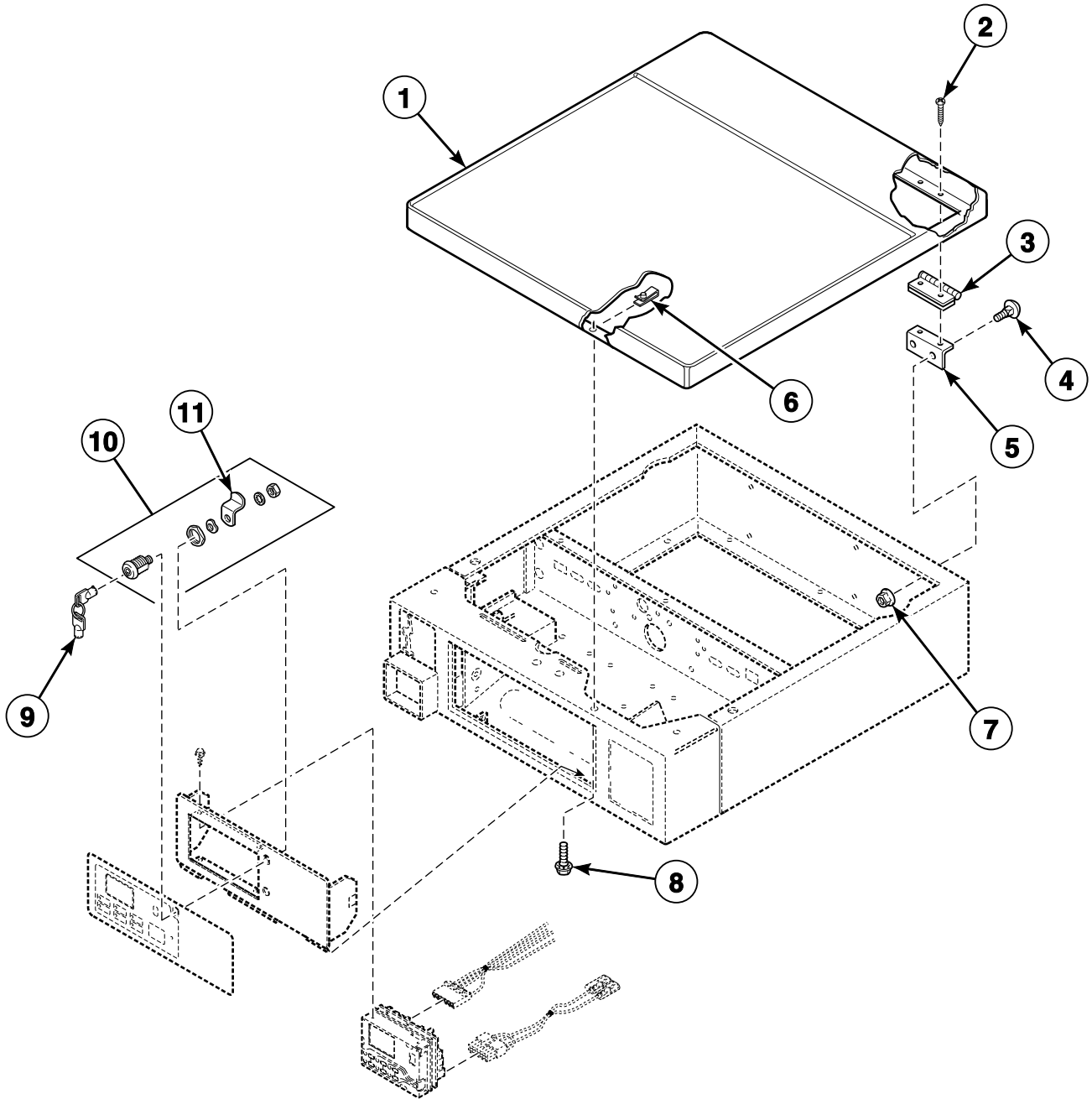

FLW1032PA_802739

Top Assembly (Drawing 2 of 2)

Models BFNBCFSG112TN01, BFNBCFSG112TW01, BFNBESP112CN01, BFNBESP112CW01, BFNBXFSP112FW01, BFNBXFSP302AW01, BFNBXFSP112TW01, HFNBCFSG112TN01, HFNBCFSG112TQ01, HFNBCFSG112TW01, HFNBCFSP112TN01, HFNBCFSP112TQ01, HFNBCFSP112TW01, HFNBDFSG112CW01, HFNBDFSP112CW01, HFNBESP112CW01, HFNBXFSP112CW01, HFNBXFSP112FQ01, HFNBXFSP122DW01, HFNBXFSP302NW22, HFNBXFSP542DW01, HFNBXFSG112CW01, HFNBXFSP112CW01, SFNBCFSG112TQ01, SFNBCFSG112TW01, SFNBCFSP112TQ01, SFNBCFSP112TW01, SFNBXFSG082JW01, SFNBXFSG112TQ01, SFNBXFSG112TW01, SFNBXFSP112TQ01, SFNBXFSP112TW01, SFNBXFSP122DW01, SFNBXFSP302AW01, SFNBXFSP302NQ01, SFNBXFSP302NW01, SFNBXFSP302NW22, SFNBXFSP542DW01, SFNBXFSG112TW01 and SFNBXFSP112TW01

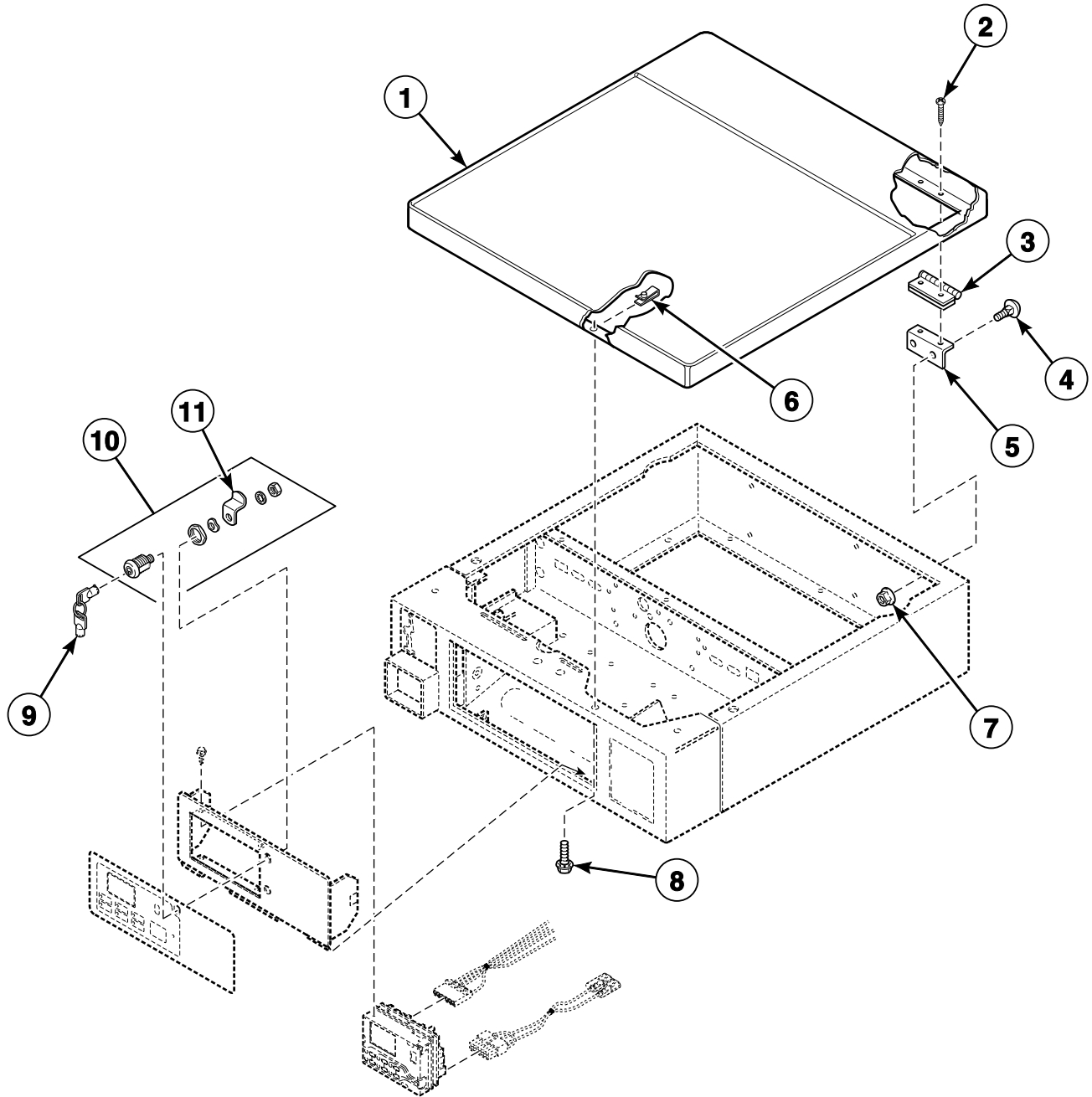

FLW1032PA_802739

Control Cabinet Controls (Drawing 1 of 2)

Models BFNBCFSG111TN01, BFNBCFSG111TW01, BFNBEFSP111CN01, BFNBEFSP111CW01, BFNBEFSP111TN01, BFNBEFSP111TW01, BWF71*N1127, BWF71*N3050, BWF74*N4000, BWF75*N4000, HFNBCFSG111TN01, HFNBCFSP111TN01, HFNCXFSP111CW01, HWFB71*N, HWFB71*N1102, HWFR71*N1102, HWFT71*N, HWFT71*N1102, HWFT73*N, HWFT73*N1102, HWFX71*N1102, HWFX71*N1127, HWFY71*N1102, HWFY73*N1102, HWFY74*N4000, HWFY75*N4000, NWF74*N4000, NWF75*N4000, SFNBXFSP301NW22, SFNCCFSP111TW01, SFNCYFSP111TW01, SWFA71*N, SWFA71*N3050, SWFA71*N3069, SWFA73*N, SWFB71*N, SWFB72*N, SWFB73*N, SWFF71*N, SWFF71*N3050, SWFF73*N, SWFT71*N, SWFT73*N, SWFX71*N, SWFX71*N1127, SWFX71*N3000, SWFX71*N3050, SWFX71*N3051, SWFX71*N5400, SWFX73*N, SWFX74*N4000, SWFX75*N4000, SWFY71*N and SWFY73*N

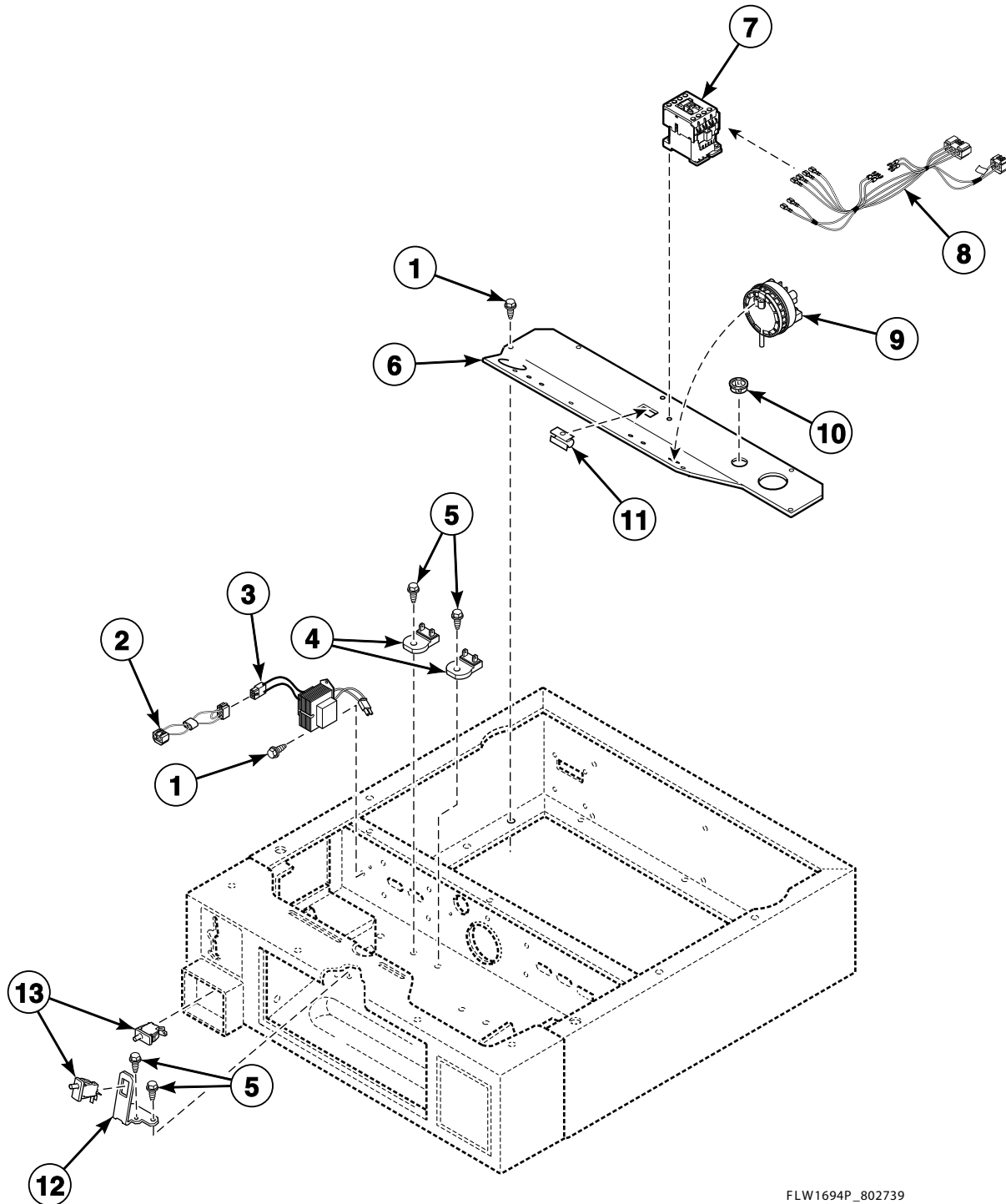

FLW1694P_802739

SWF 3 P5

© Copyright, Alliance Laundry Systems LLC – DO NOT COPY or TRANSMIT

Control Cabinet Controls (Drawing 2 of 2)

Models BFNBCFSG112TN01, BFNBCFSG112TW01, BFNBESP112CN01, BFNBESP112CW01, BFNBXFSP112FW01, BFNBXFSP302AW01, BFNBXFSP112TW01, HFNBCFSG112TN01, HFNBCFSG112TQ01, HFNBCFSG112TW01, HFNBCFSP112TN01, HFNBCFSP112TQ01, HFNBCFSP112TW01, HFNBDFSG112CW01, HFNBDFSP112CW01, HFNBESP112CW01, HFNBXFSP112CW01, HFNBXFSP112FQ01, HFNBXFSP122DW01, HFNBXFSP302NW22, HFNBXFSP542DW01, HFNBXFSG112CW01, HFNBXFSP112CW01, SFNBCFSG112TQ01, SFNBCFSG112TW01, SFNBESP112TQ01, SFNBESP112TW01, SFNBXFSG082JW01, SFNBXFSG112TQ01, SFNBXFSG112TW01, SFNBXFSP112TQ01, SFNBXFSP112TW01, SFNBXFSP122DW01, SFNBXFSP302AW01, SFNBXFSP302NQ01, SFNBXFSP302NW01, SFNBXFSP302NW22, SFNBXFSP542DW01, SFNBXFSG112TW01 and SFNBXFSP112TW01

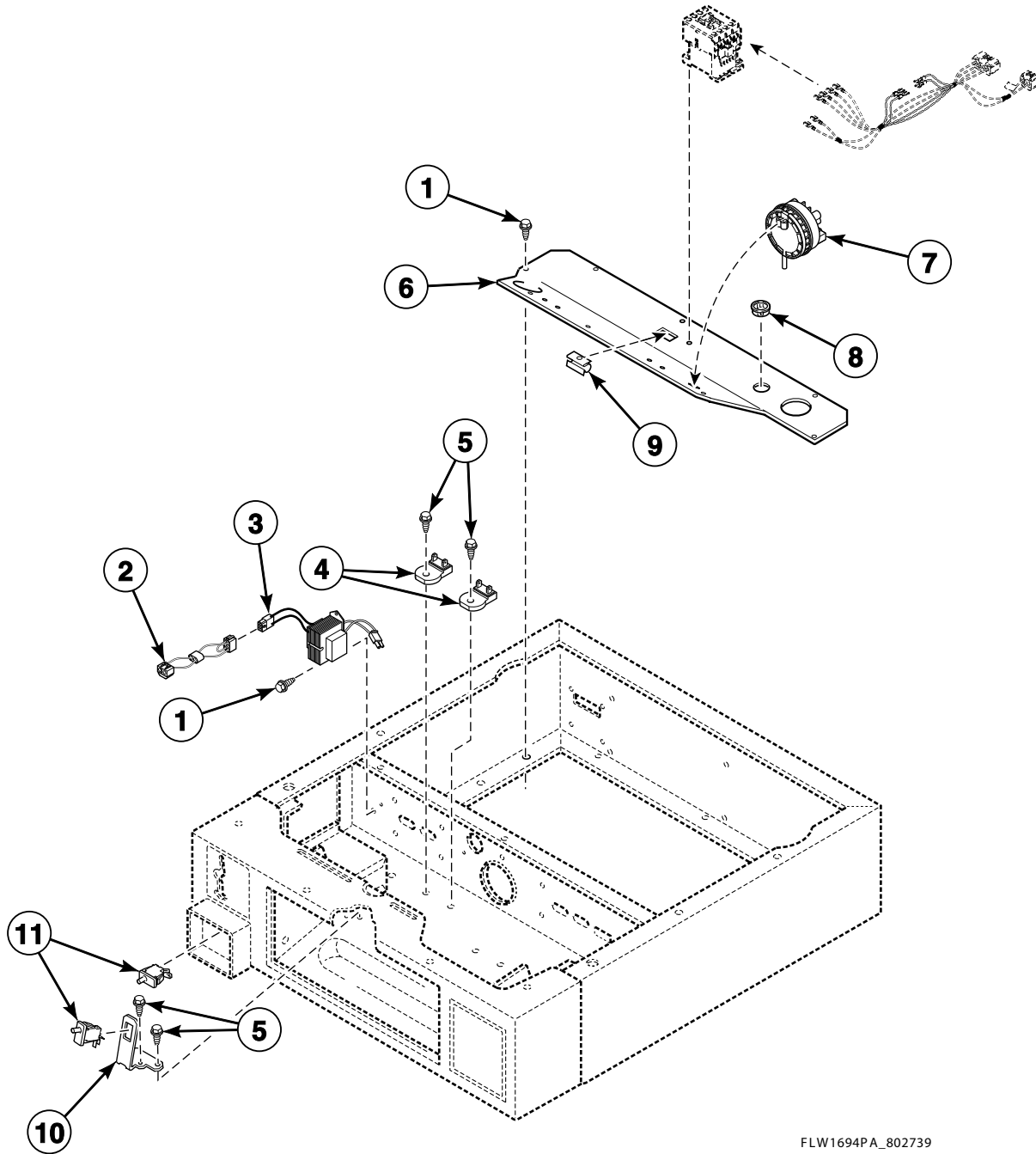

FLW1694PA_802739

Control Cabinet and Controls

Models BFNBLFSP301AW01, BFNBLFSP302AW01, BFNBLFSP541NW01,
BFNBLFSP542NW01, BWFL74*N4000, BWFL75*N4000, NWFL84*N4000,
NWFL85*N4000 and SWFL74*N4000

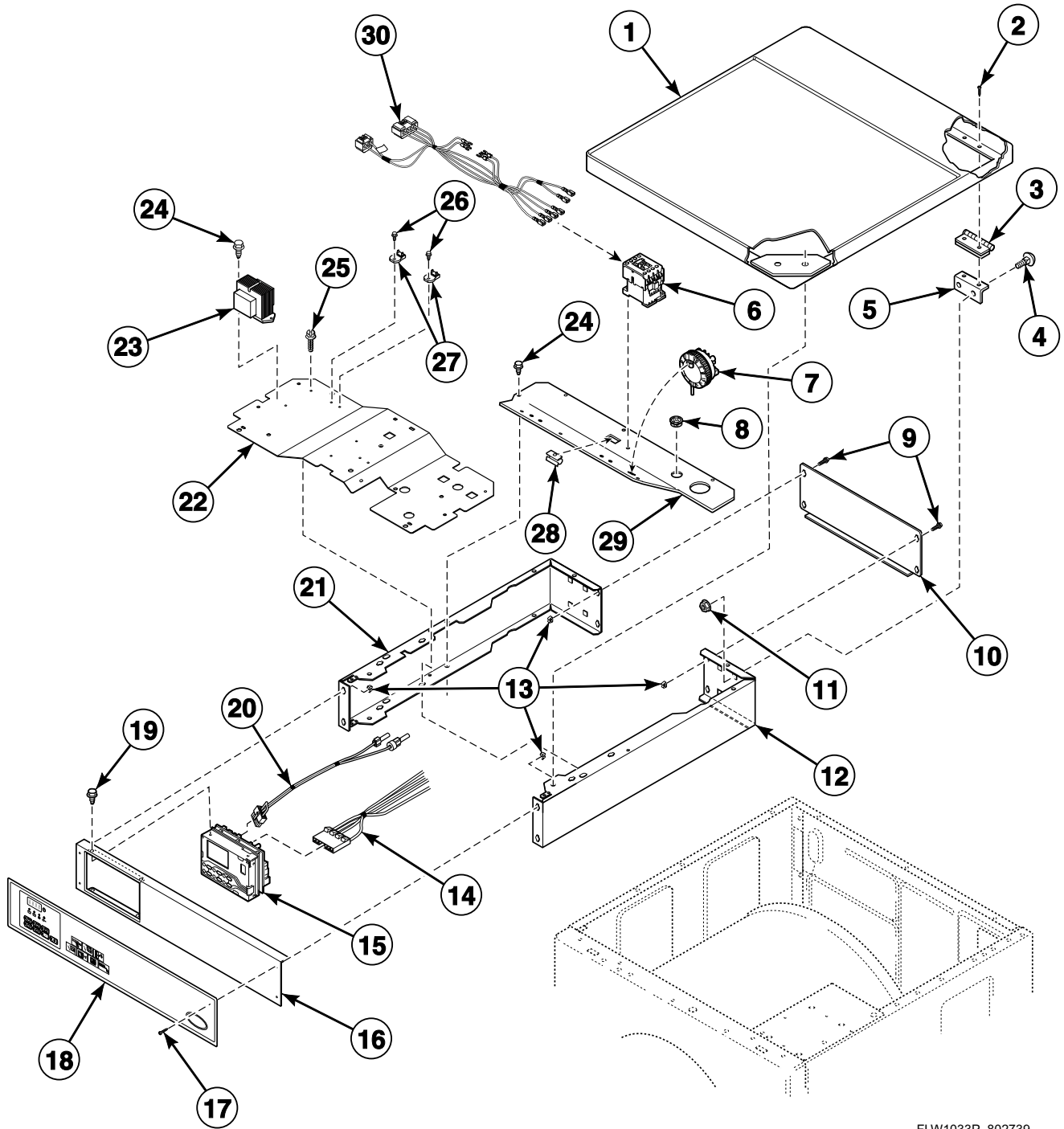

FLW1033P_802739

Electrical Access Panel, Filters and Terminal Block

Models BFNBLFSP301AW01, BFNBLFSP302AW01, BFNBLFSP541NW01, BFNBLFSP542NW01, BWFL74*N4000, BWFL75*N4000, BWFX74*N4000, BWFX75*N4000, HWFY74*N4000, HWFY75*N4000, NWFL84*N4000, NWFL85*N4000, NWFX74*N4000, NWFX75*N4000, SWFL74*N4000, SWFX74*N4000 and SWFX75*N4000

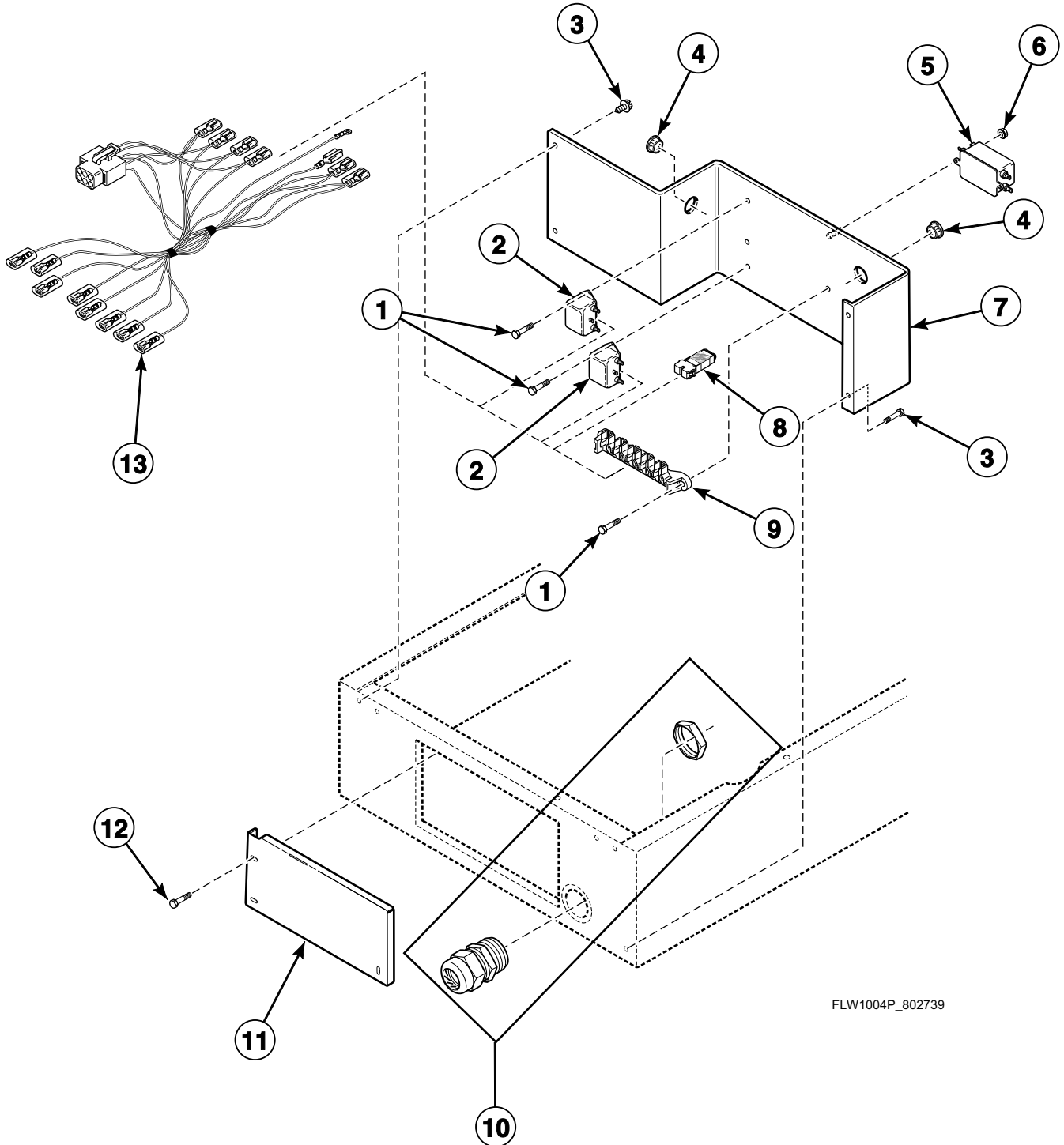

FLW1004P_802739

Wrapper Assembly

Models BFNBCFSG111TN01, BFNBCFSG111TW01, BFNBCFSG112TN01, BFNBCFSG112TW01, BFNBESP111CN01, BFNBESP111CW01, BFNBESP111TN01, BFNBESP111TW01, BFNBESP112CN01, BFNBESP112CW01, BFNBXFSP112FW01, BFNBXFSP302AW01, BWF71*N1127, BWF71*N3050, BWF74*N4000, BWF75*N4000, HFNBCFSG111TN01, HFNBCFSG112TN01, HFNBCFSG112TQ01, HFNBCFSG112TW01, HFNBCFSP111TN01, HFNBCFSP112TN01, HFNBCFSP112TQ01, HFNBCFSP112TW01, HFNBDFSG112CW01, HFNBDFSP112CW01, HFNBESP112CW01, HFNBXFSP112CW01, HFNBXFSP112FQ01, HFNBXFSP122DW01, HFNBXFSP302NW22, HFNBXFSP542DW01, HFNCXFSP111CW01, HWFB71*N, HWFB71*N1102, HWFR71*N1102, HWFT71*N, HWFT71*N1102, HWFT73*N, HWFT73*N1102, HWFX71*N1102, HWFX71*N1127, NWF74*N4000, NWF75*N4000, SFNBCFSG112TQ01, SFNBCFSG112TW01, SFNBCFSP112TQ01, SFNBCFSP112TW01, SFNBXFSG082JW01, SFNBXFSP112TQ01, SFNBXFSP112TW01, SFNBXFSP112TQ01, SFNBXFSP112TW01, SFNBXFSP122DW01, SFNBXFSP122DW01, SFNBXFSP301NW22, SFNBXFSP302AW01, SFNBXFSP302NQ01, SFNBXFSP302NW01, SFNBXFSP302NW22, SFNBXFSP542DW01, SFNCCFSP111TW01, SWFA71*N, SWFA71*N3050, SWFA71*N3069, SWFA73*N, SWFB71*N, SWFB72*N, SWFB73*N, SWFT71*N, SWFT73*N, SWFX71*N, SWFX71*N1127, SWFX71*N3000, SWFX71*N3050, SWFX71*N3051, SWFX71*N5400, SWFX73*N, SWFX74*N4000 and SWFX75*N4000

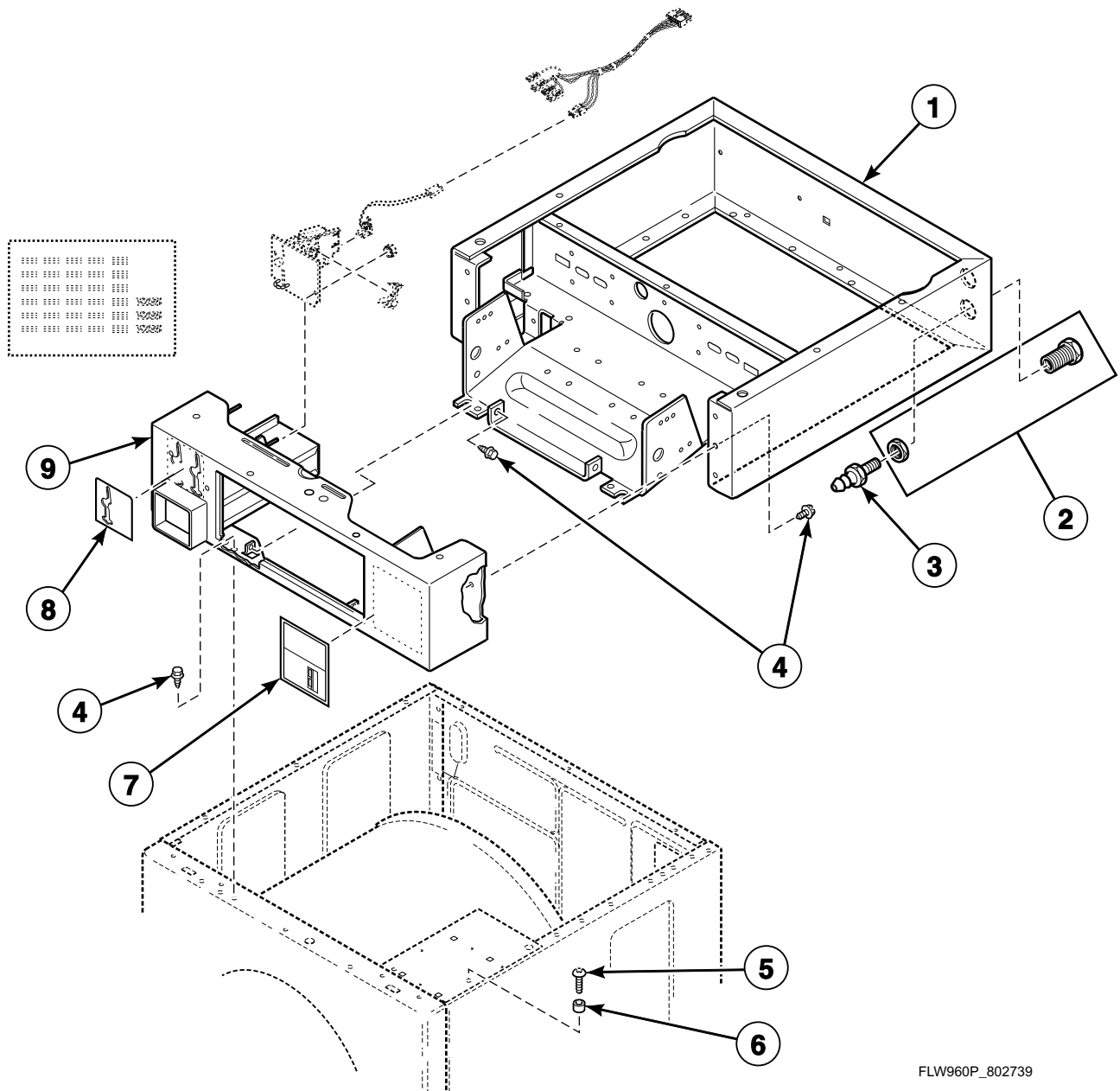

FLW960P_802739

SWF 3 P9

© Copyright, Alliance Laundry Systems LLC – DO NOT COPY or TRANSMIT

Non-Electronic Coin Drop

Models BFNBCFSG111TN01, BFNBCFSG111TW01, BFNBCFSG112TN01, BFNBCFSG112TW01, BFNBDFSP112CN01, BFNBDFSP112CW01, BFNBXFSP112FW01, BFNBXFSP302AW01, BWF71*N1127, BWF71*N3050, BWF74*N4000, BWF75*N4000, HFNBCFSG111TN01, HFNBCFSG112TN01, HFNBCFSG112TQ01, HFNBCFSG112TW01, HFNBDFSP111TN01, HFNBDFSP112TN01, HFNBDFSP112TQ01, HFNBDFSP112TW01, HFNBDFSG112CW01, HFNBDFSP112CW01, HFNBDFSP112CW01, HFNBDFSP112FQ01, HFNBDFSP122DW01, HFNBDFSP302NW22, HFNBDFSP542DW01, HFNBDFSP111CW01, HWFB71*N, HWFB71*N1102, HWFR71*N1102, HWFT71*N, HWFT71*N1102, HWFT73*N, HWFT73*N1102, HWFX71*N1102, HWFX71*N1127, NWF74*N4000, NWF75*N4000, SFNBCFSG112TQ01, SFNBCFSG112TW01, SFNBDFSP112TQ01, SFNBDFSP112TW01, SFNBDFSG082JW01, SFNBDFSG112TQ01, SFNBDFSG112TW01, SFNBDFSP112TQ01, SFNBDFSP112TW01, SFNBDFSP122DW01, SFNBDFSP301NW22, SFNBDFSP302AW01, SFNBDFSP302NQ01, SFNBDFSP302NW01, SFNBDFSP302NW22, SFNBDFSP542DW01, SFNBDFSP111TW01, SWFA71*N, SWFA71*N3050, SWFA71*N3069, SWFA73*N, SWFB71*N, SWFB72*N, SWFB73*N, SWFT71*N, SWFT73*N, SWFX71*N, SWFX71*N1127, SWFX71*N3000, SWFX71*N3050, SWFX71*N3051, SWFX71*N5400, SWFX73*N, SWFX74*N4000 and SWFX75*N4000

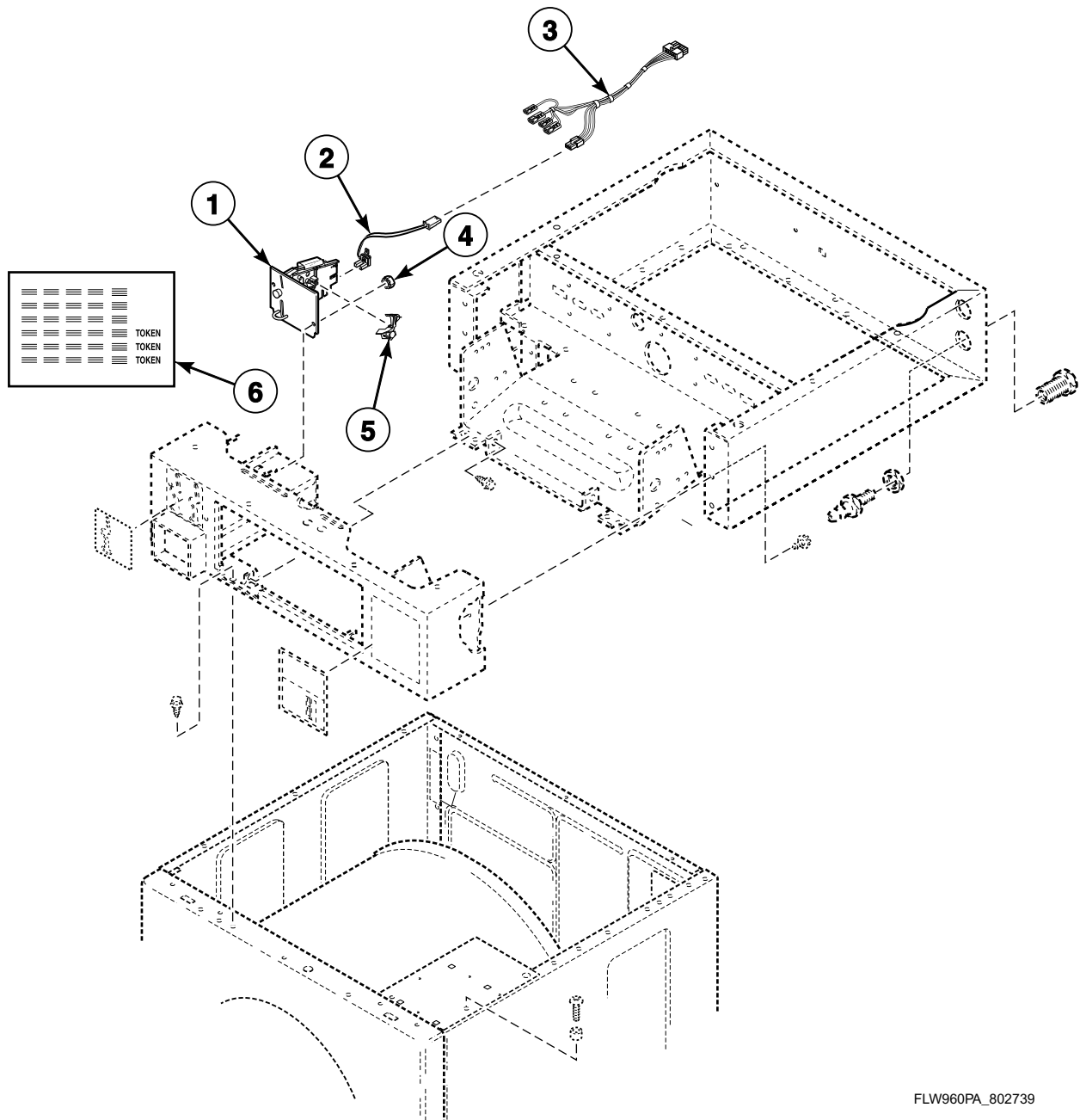

FLW960PA_802739

SWF 3 P10

© Copyright, Alliance Laundry Systems LLC – DO NOT COPY or TRANSMIT

Electronic Coin Drop

Models BFNBCFSG111TN01, BFNBCFSG111TW01, BFNBCFSG112TN01, BFNBCFSG112TW01, BFNBEFSP111CN01, BFNBEFSP111CW01, BFNBEFSP111TN01, BFNBEFSP111TW01, BFNBEFSP112CN01, BFNBEFSP112CW01, BFNBFSP112FW01, BFNBFSP302AW01, BWF71*N1127, BWF71*N3050, BWF74*N4000, BWF75*N4000, HFNBCFSG111TN01, HFNBCFSG112TN01, HFNBCFSG112TQ01, HFNBCFSG112TW01, HFNBCFSP111TN01, HFNBCFSP112TN01, HFNBCFSP112TQ01, HFNBCFSP112TW01, HFNBDRSP112TW01, HFNBDFSG112CW01, HFNBDFSP112CW01, HFNBDRSP112CW01, HFNBDFSP112CW01, HFNBERSP112CW01, HFNBXFSP112CW01, HFNBXFSP112FQ01, HFNBXFSP122DW01, HFNBXFSP302NW22, HFNBXFSP542DW01, HFNBXRSP112FW28, HFNCXFSP111CW01, HFNCXRSP111CW01, HWFB71*N, HWFB71*N1102, HWFR71*N1102, HWFT71*N, HWFT71*N1102, HWFT73*N, HWFT73*N1102, HWFX71*N1102, HWFX71*N1127, HWRR71*N1102, HWRT71*N, HWRT71*N1102, HWRX71*N1102, NWF74*N4000, NWF75*N4000, SFNBCFSG112TQ01, SFNBCFSG112TW01, SFNBCFSP112TQ01, SFNBCFSP112TW01, SFNBDRSP111TW02, SFNBDRSP112TW01, SFNBDRSP112TW02, SFNBXFSG082JW01, SFNBXFSG112TQ01, SFNBXFSG112TW01, SFNBXFSP112TQ01, SFNBXFSP112TW01, SFNBXFSP122DW01, SFNBXFSP301NW22, SFNBXFSP302AW01, SFNBXFSP302NQ01, SFNBXFSP302NW01, SFNBXFSP302NW22, SFNBXFSP542DW01, SFNBXRSP112TW01, SFNBXRSP112TW02, SFNCCFSP111TW01, SFNCCRSP111TW01, SFNCCRSP111TW02, SFNCXRSP111TW02, SWFA71*N, SWFA71*N3050, SWFA71*N3069, SWFA73*N, SWFB71*N, SWFB72*N, SWFB73*N, SWFT71*N, SWFT73*N, SWFX71*N, SWFX71*N1127, SWFX71*N3000, SWFX71*N3050, SWFX71*N3051, SWFX71*N5400, SWFX73*N, SWFX74*N4000, SWFX75*N4000, SWRB71*N, SWRT71*N, SWRT73*N and SWRX71*N

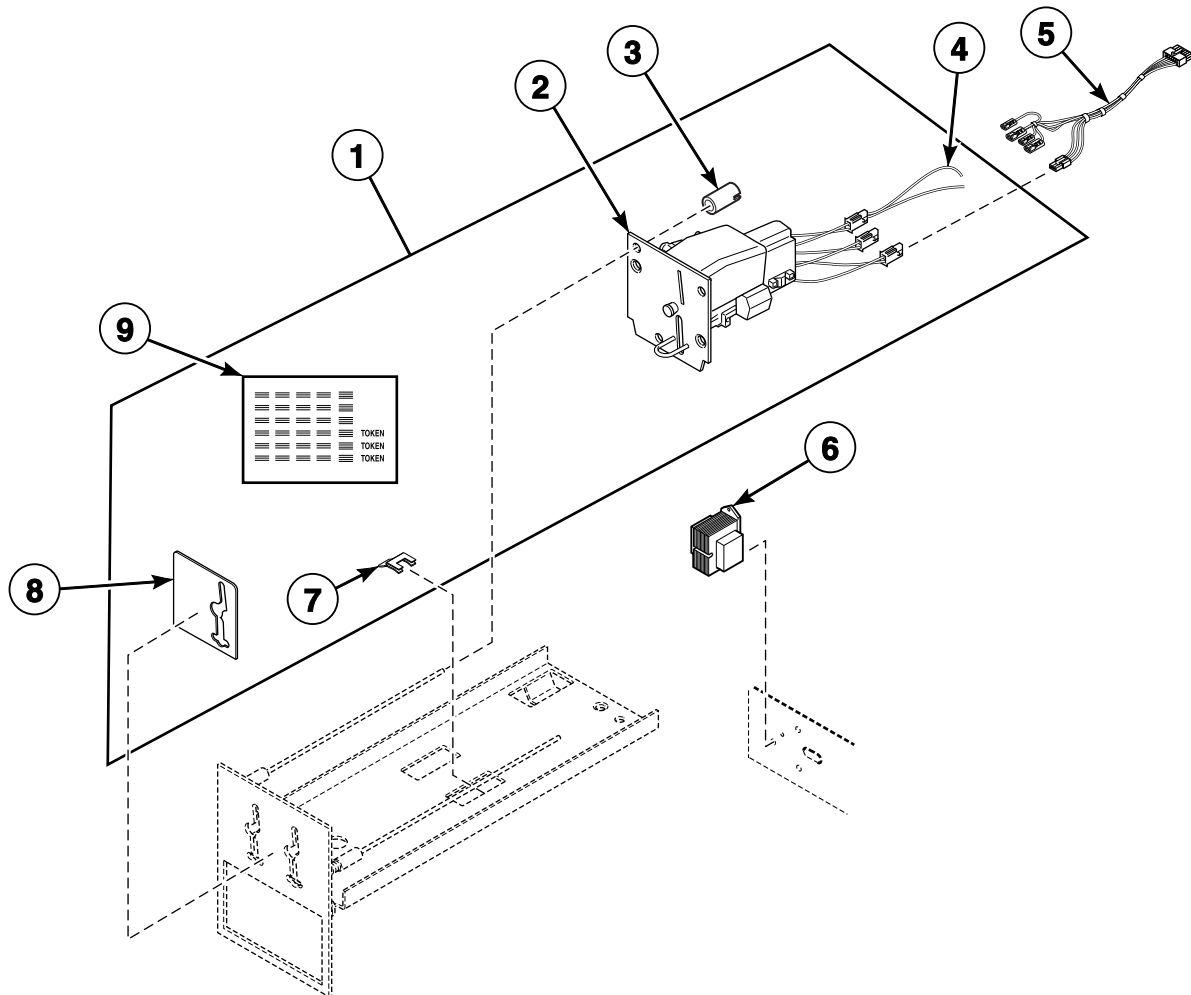

FLW1005P_802739

SWF 3 P11

© Copyright, Alliance Laundry Systems LLC – DO NOT COPY or TRANSMIT

Wrapper Assembly and Card Reader

Models BFNBYFSP112TW01, HFNBYSFG112CW01, HFNBYSFG112CW01, HWFY71*N1102, HWFY73*N1102, HWFY74*N4000, HWFY75*N4000, SFNBYSFG112TW01, SFNBYSFG112TW01, SFNBYFSP111TW01, SWFF71*N, SWFF71*N3050, SWFF73*N, SWFY71*N and SWFY73*N

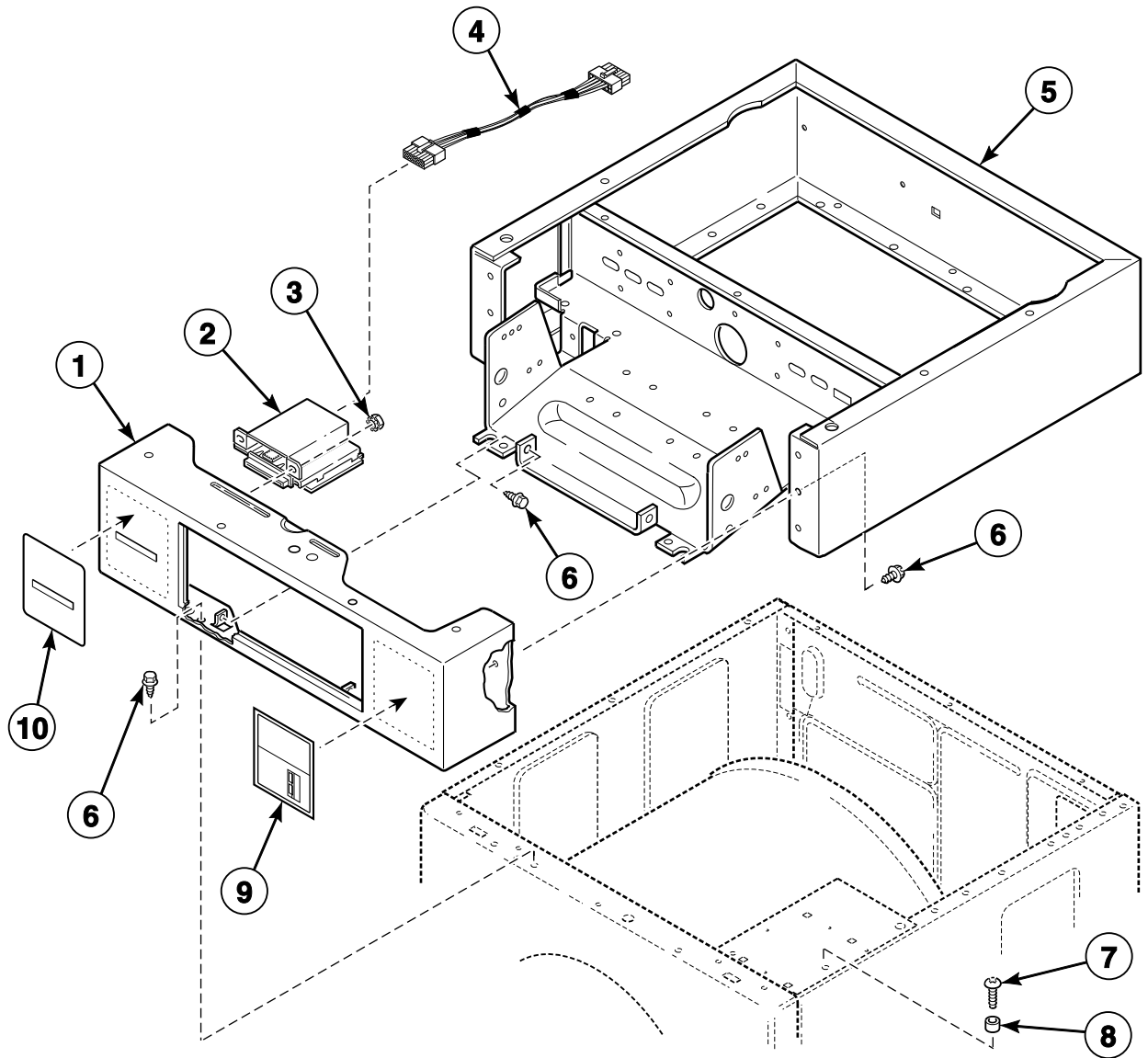

FLW898P_802739

SWF 3 P12

© Copyright, Alliance Laundry Systems LLC – DO NOT COPY or TRANSMIT

Non-Electronic Coin Drop, Meter Case and Service Door

Models HFNBCRSP112TW01, HFNBDRSP112CW01, HFNBERSP112CW01,
HFNBXRSP112FW28, HFNCXRSP111CW01, HWRR71*N1102, HWRT71*N,
HWRT71*N1102, HWRX71*N1102, SFNBCRSP111TW02, SFNBCRSP112TW01,
SFNBCRSP112TW02, SFNBXRSP112TW01, SFNBXRSP112TW02,
SFNCCRSP111TW01, SFNCCRSP111TW02, SFNCXRSP111TW02, SWRB71*N,
SWRT71*N, SWRT73*N and SWRX71*N

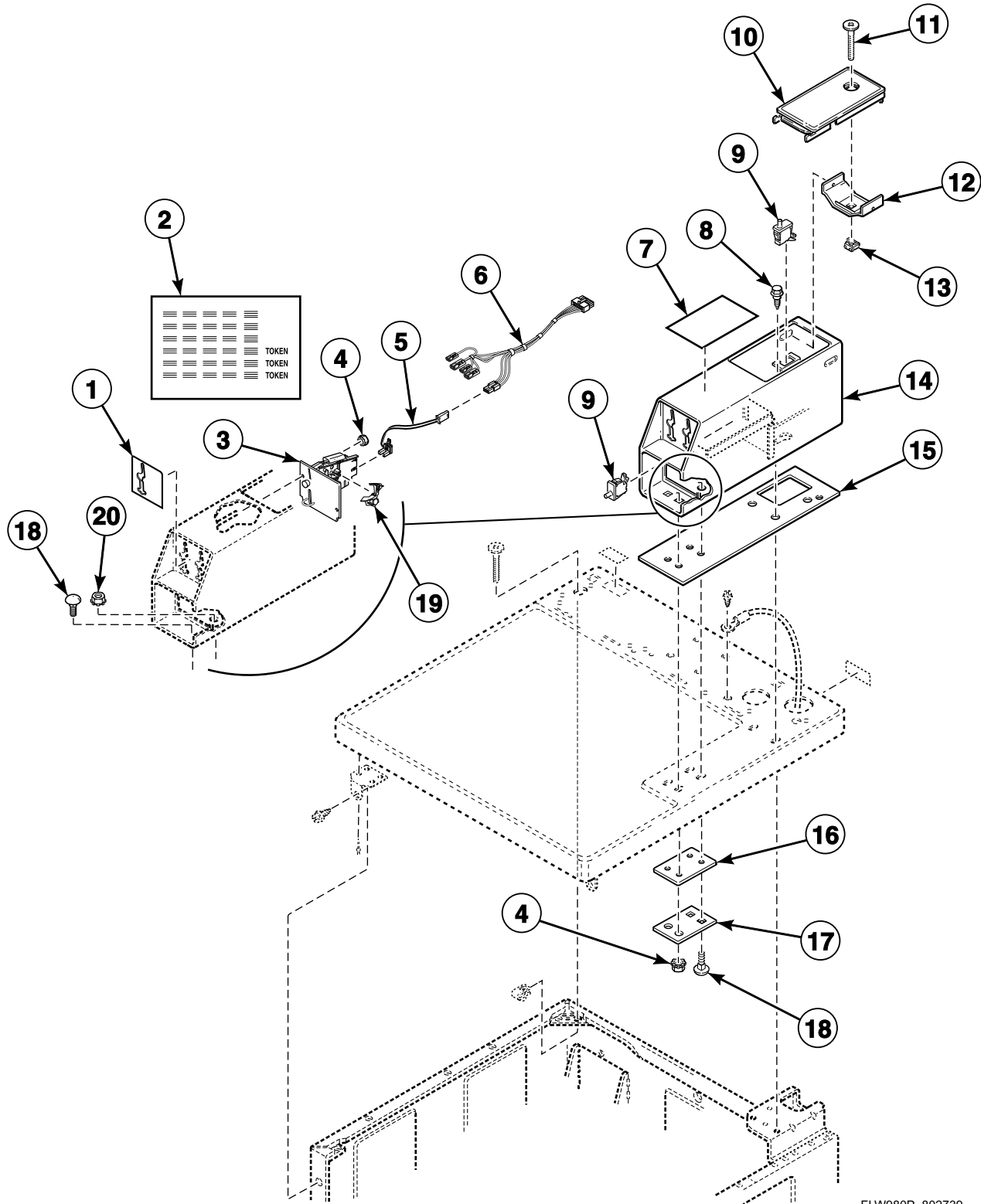

FLW980P_802739

Cabinet Top

Models HFNBCRSP112TW01, HFNBDRSP112CW01, HFNBERSP112CW01, HFNBXRSP112FW28, HFNCXRSP111CW01, HWRR71*N1102, HWRT71*N, HWRT71*N1102, HWRX71*N1102, SFNBCRSP111TW02, SFNBCRSP112TW01, SFNBCRSP112TW02, SFNBXRSP112TW01, SFNBXRSP112TW02, SFNCCRSP111TW01, SFNCCRSP111TW02, SFNCXRSP111TW02, SWRB71*N, SWRT71*N, SWRT73*N and SWRX71*N

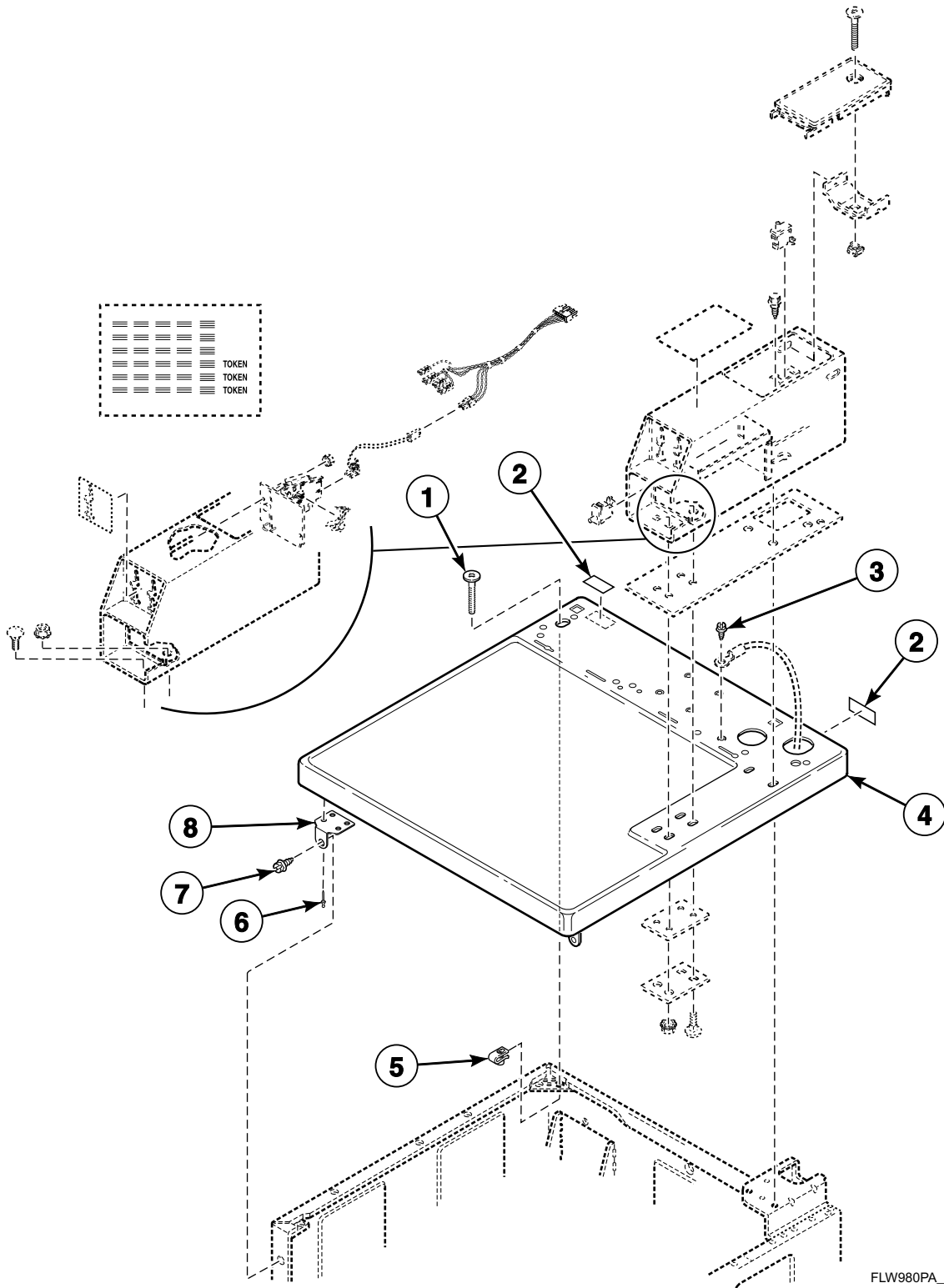

FLW980PA_802739

Meter Case, Service Door and Cabinet Top

Models HFNSXRSP112CW01, HWR971*N1102, HWR971*N1127, HWR973*N1102, SFNSXRSP111TW02, SFNSXRSP112TQ01, SFNSXRSP112TW01, SFNSXRSP112TW02, SFNSXRSP541NQ23, SFNSXRSP541NW23, SFNTRSP111TW01, SFNTRSP111TW02, SWR971*N and SWR973*N

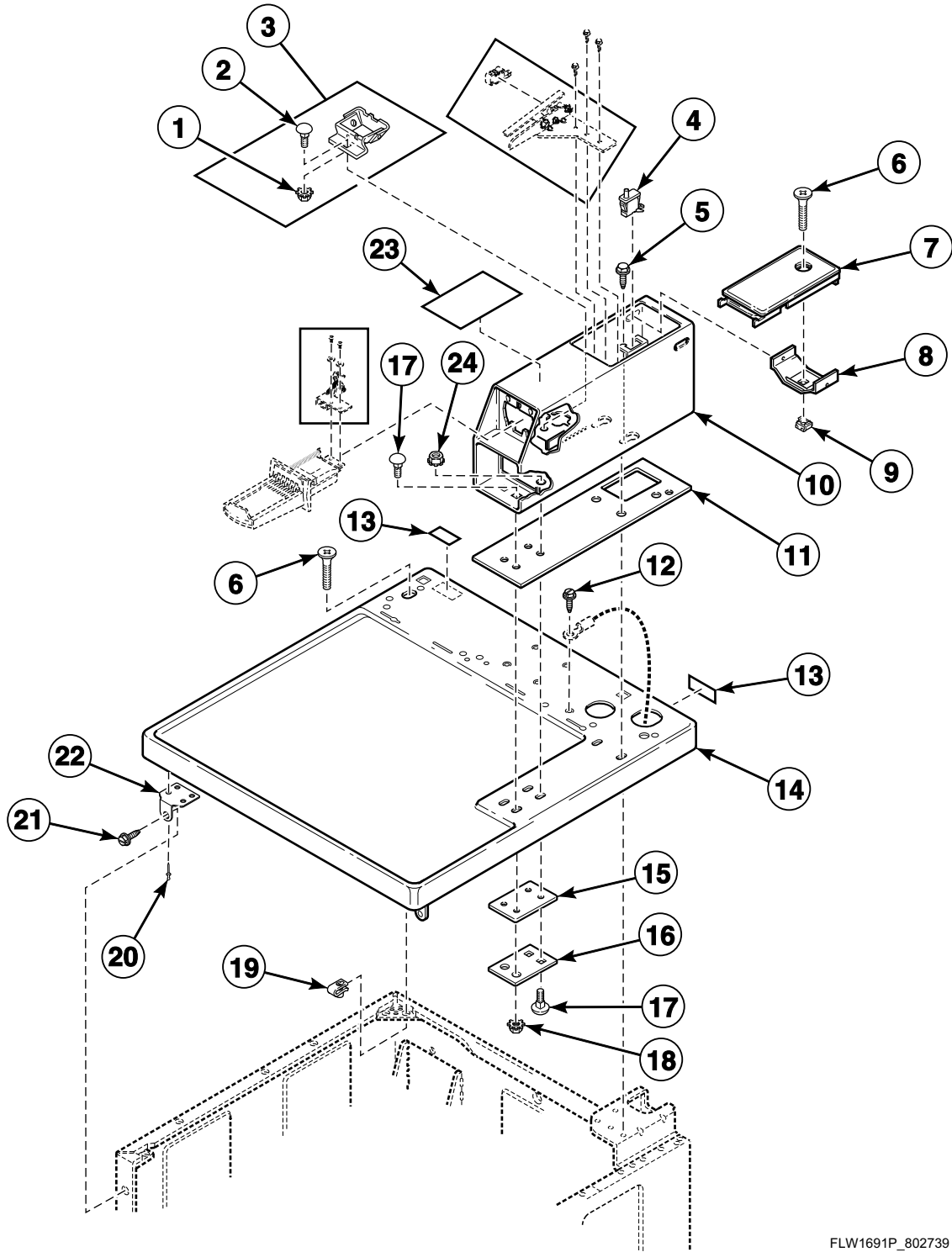

FLW1691P_802739

Coin Slide Extension Through Serial No. 1211

Models HWR971*N1102, HWR971*N1127, HWR973*N1102, SFNSXRSP112TW02, SFNSXRSP541NQ23, SFNSXRSP541NW23, SFNTRSP111TW01, SFNTRSP111TW02, SWR971*N and SWR973*N

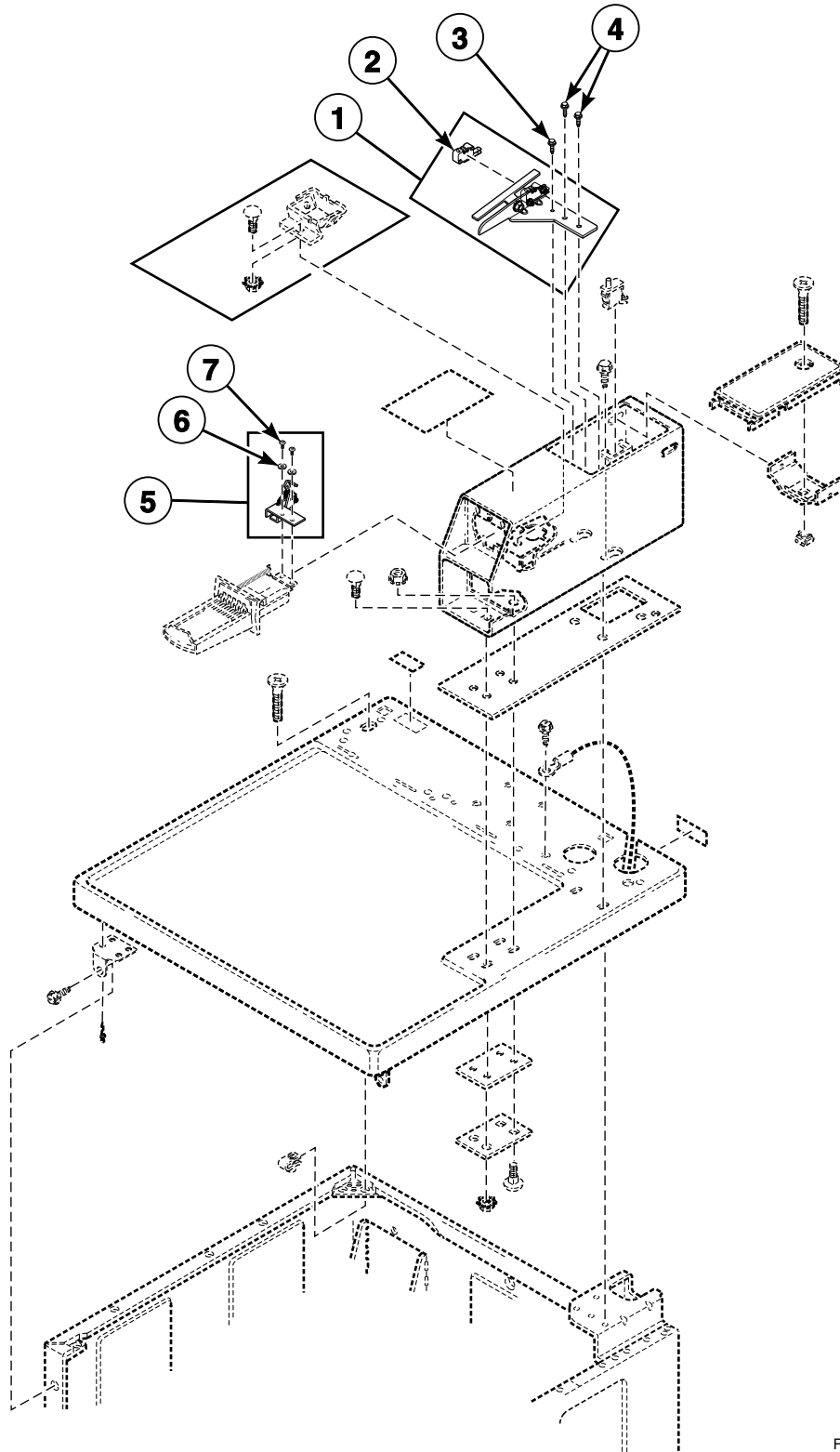

FLW1691PA_802739

SWF 3 P16

© Copyright, Alliance Laundry Systems LLC – DO NOT COPY or TRANSMIT

Coin Slide Extension Starting Serial No. 1211

Models HFNSXRSP112CW01, HWR971*N1102, HWR971*N1127, HWR973*N1102, SFNSXRSP111TW02, SFNSXRSP112TQ01, SFNSXRSP112TW01, SFNSXRSP112TW02, SFNSXRSP541NQ23, SFNSXRSP541NW23, SFNTRSP111TW01, SFNTRSP111TW02, SWR971*N and SWR973*N

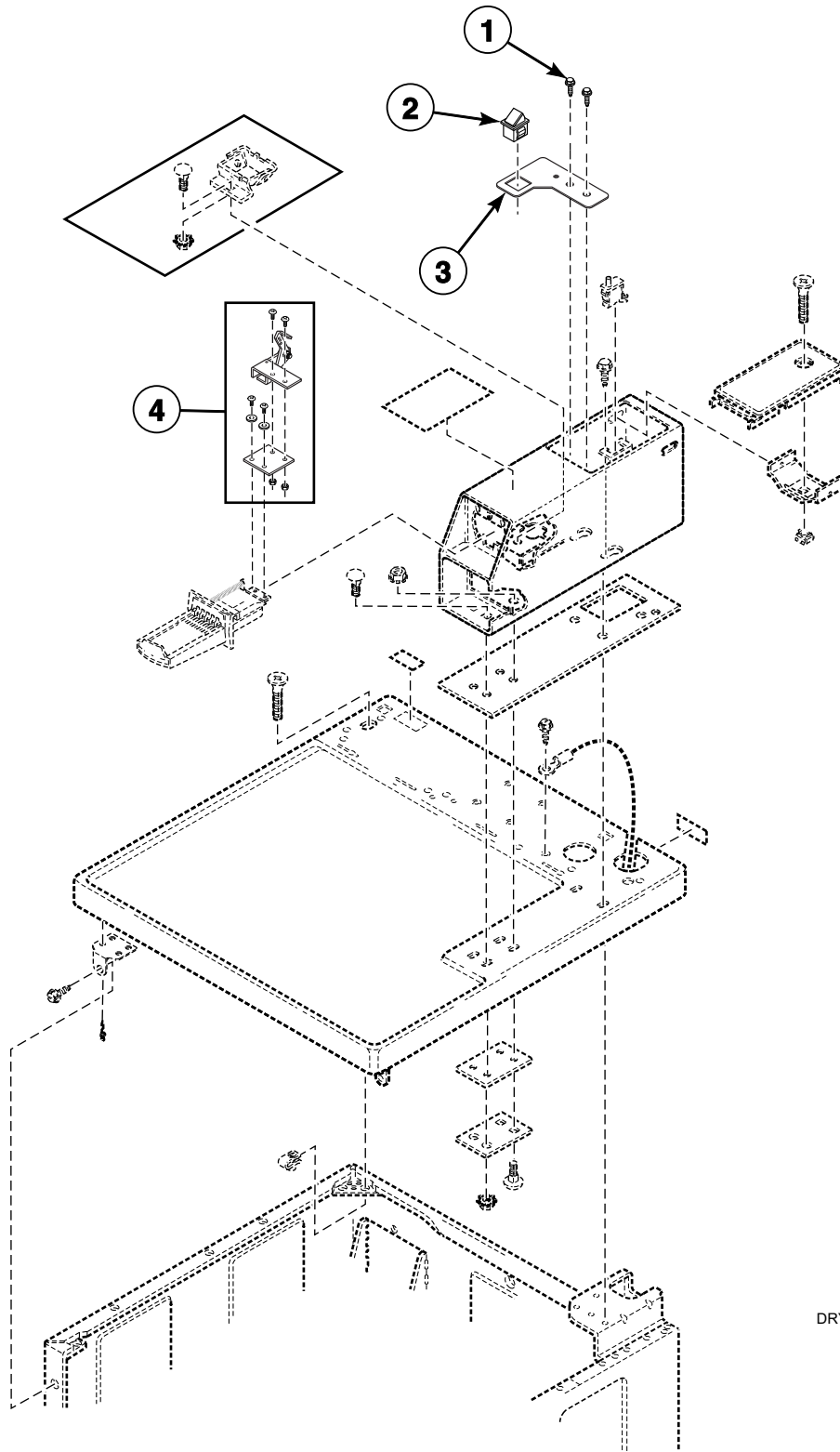

DRY2282P_802739

Control Panel, Control Hood and Controls (Drawing 1 of 3)

Models HFNBCRSP112TW01, HFNBDRSP112CW01, HFNBERSP112CW01, HFNBXRSP112FW28, HFNCXRSP111CW01, HWRR71*N1102, HWRT71*N, HWRT71*N1102, HWRX71*N1102, SFNBCRSP111TW02, SFNBCRSP112TW01, SFNBCRSP112TW02, SFNBXRSP112TW01, SFNBXRSP112TW02, SFNCCRSP111TW01, SFNCCRSP111TW02, SFNCXRSP111TW02, SWRB71*N, SWRT71*N, SWRT73*N and SWRX71*N

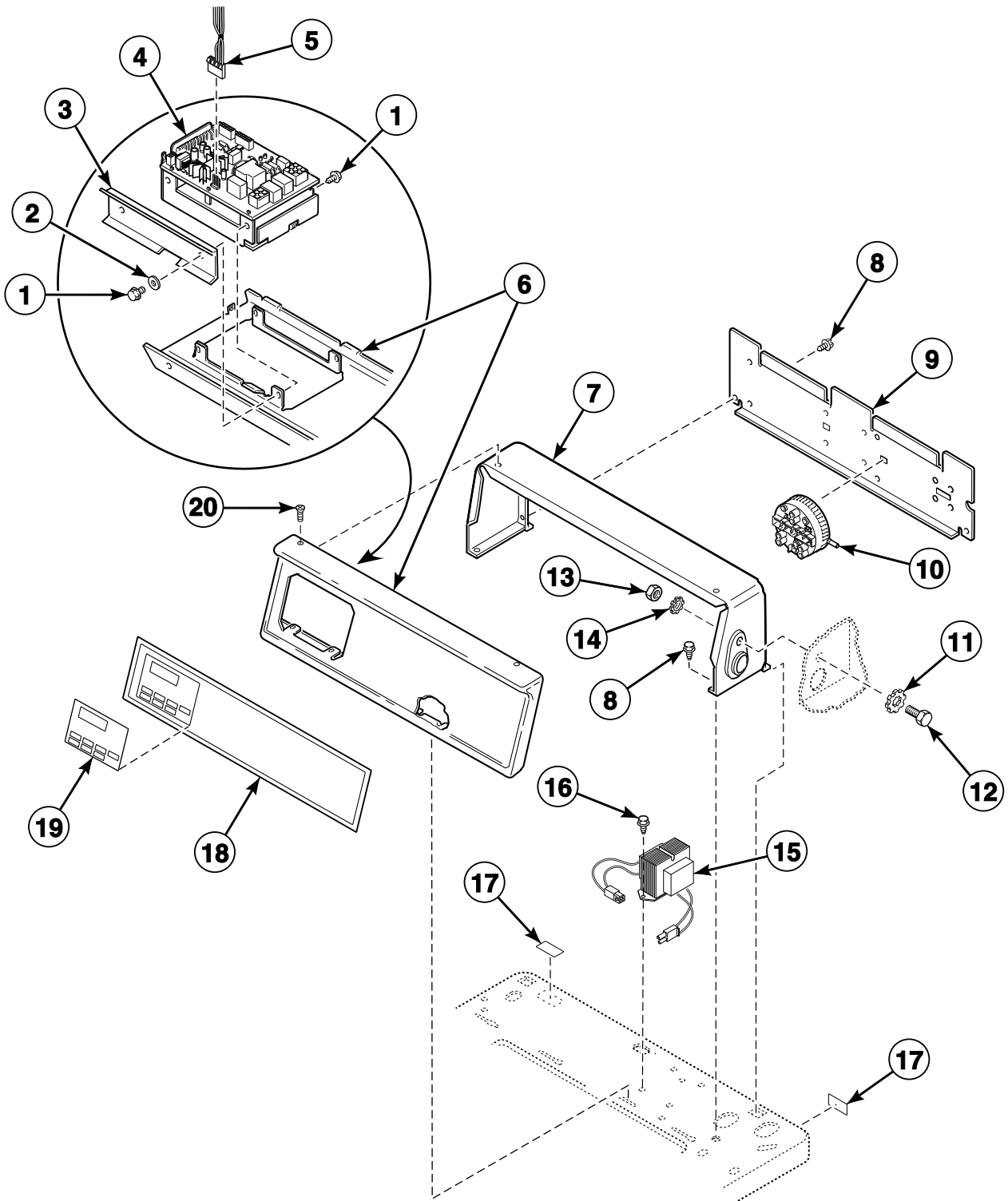

FLW1681P_802739

SWF 3 P18

Control Hood Security Kit

Models HFNBCRSP112TW01, HFNBDRSP112CW01, HFNBERSP112CW01, HFNBXRSP112FW28,
HFNCXRSP111CW01, HWRR71*N1102, HWRT71*N, HWRT71*N1102, HWRX71*N1102,
SFNBCRSP111TW02, SFNBCRSP112TW01, SFNBCRSP112TW02, SFNBXRSP112TW01,
SFNBXRSP112TW02, SFNCCRSP111TW01, SFNCCRSP111TW02, SFNCXRSP111TW02, SWRB71*N,
SWRT71*N, SWRT73*N and SWRX71*N

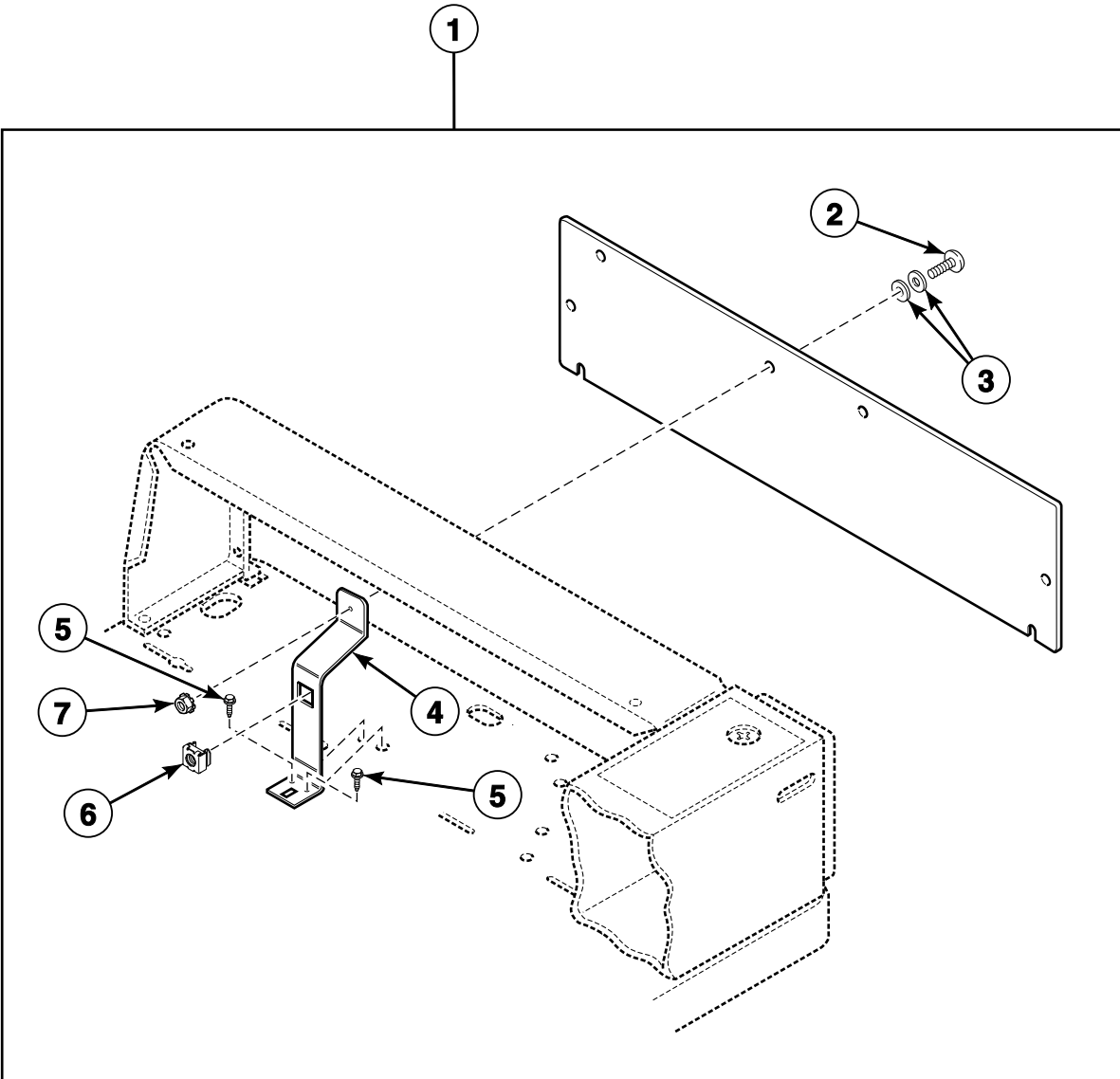

FLW963P_802739

Control Panel, Control Hood and Controls (Drawing 2 of 3)

Models HFNSXRSP112CW01, HWR971*N1102, HWR971*N1127, HWR973*N1102, SFNSXRSP111TW02, SFNSXRSP112TQ01, SFNSXRSP112TW01, SFNSXRSP112TW02, SFNSXRSP541NQ23, SFNSXRSP541NW23, SFNTRSP111TW01, SFNTRSP111TW02, SWR971*N and SWR973*N

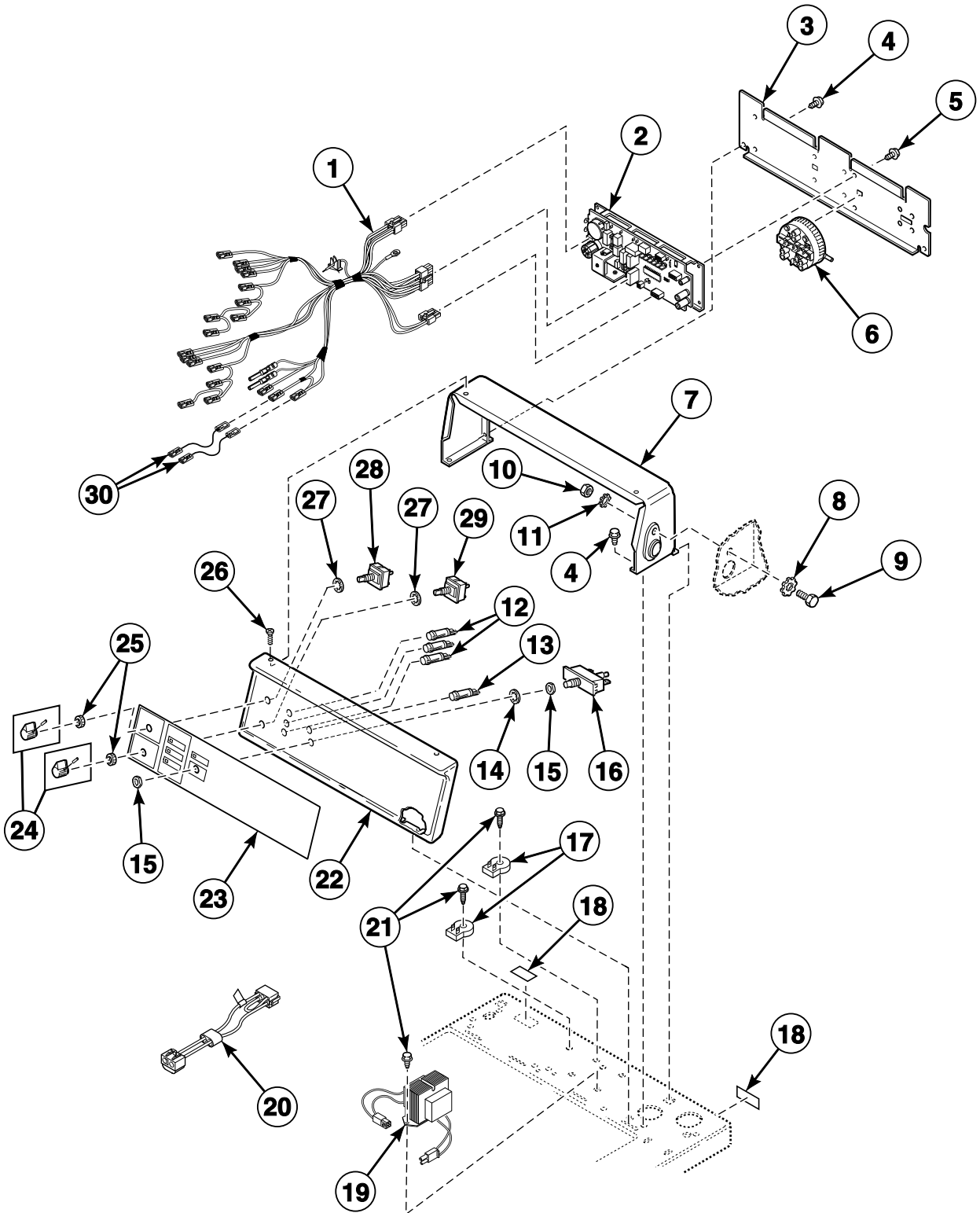

FLW1679P_802739

SWF 3 P20

Control Panel, Control Hood and Controls (Drawing 3 of 3)

Models HFNBYSRSP112CW01, HWRY71*N1102, SFNBYSRSP112TW01, SFNYSRSP111TW01, SWRF71*N and SWRY71*N

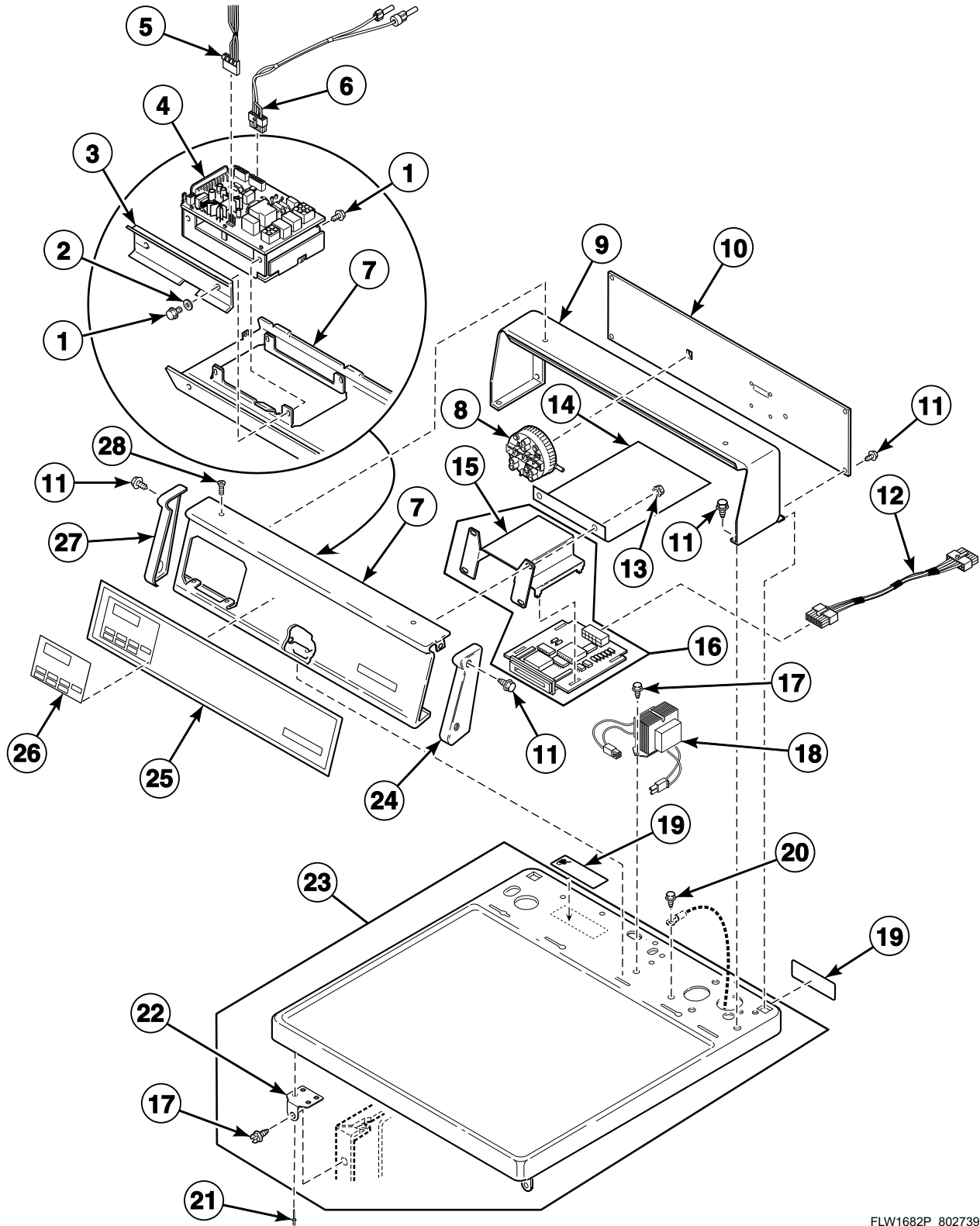

FLW1682P_802739

SWF 3 P21

© Copyright, Alliance Laundry Systems LLC – DO NOT COPY or TRANSMIT

Door Assembly

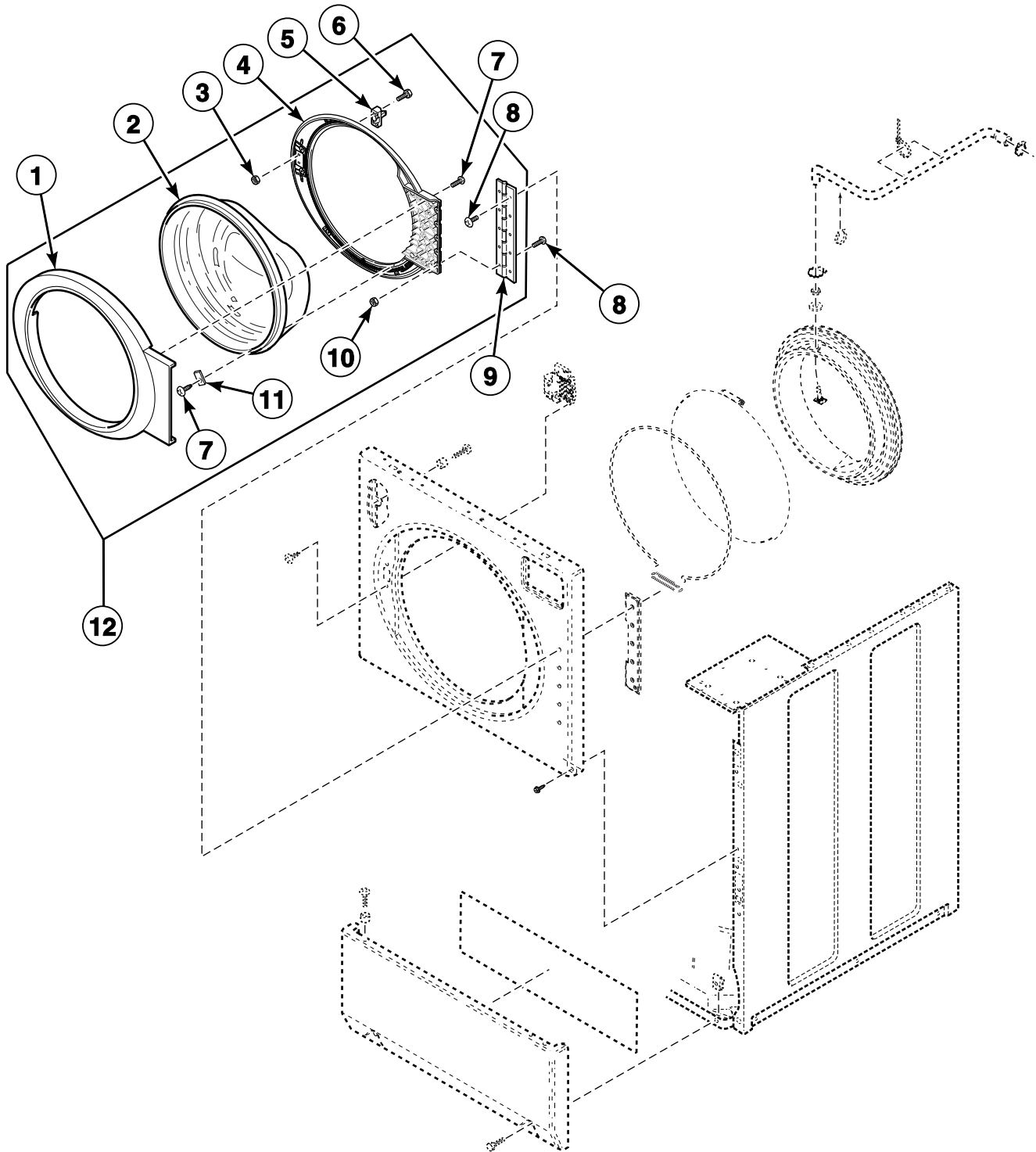

FLW938P_802739

SWF 3 P22

© Copyright, Alliance Laundry Systems LLC – DO NOT COPY or TRANSMIT

Front Panel and Door Seal

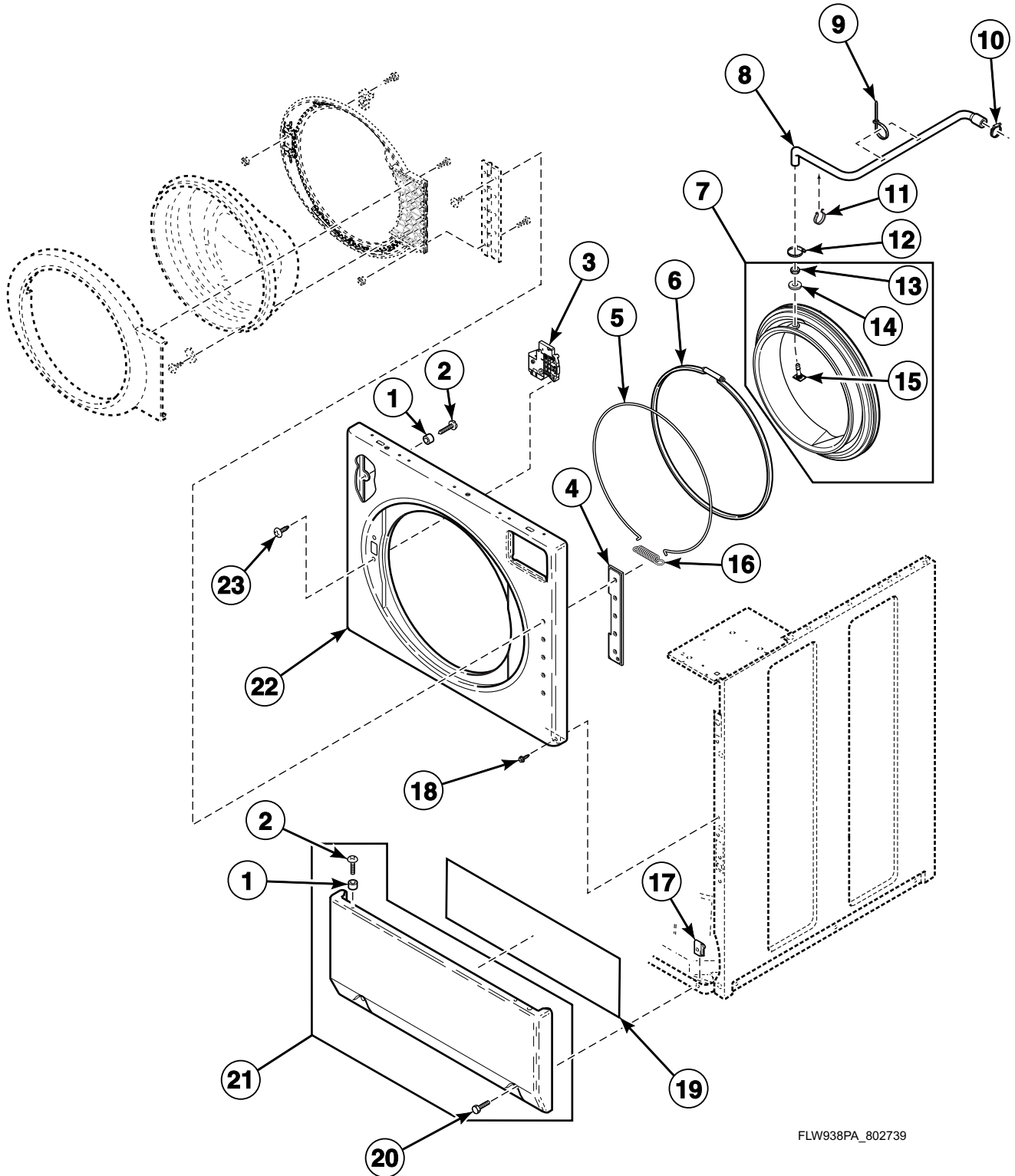

FLW938PA_802739

SWF 3 P23

Dispenser Assembly and Supply Injection Hoses

Model SWFB72*N

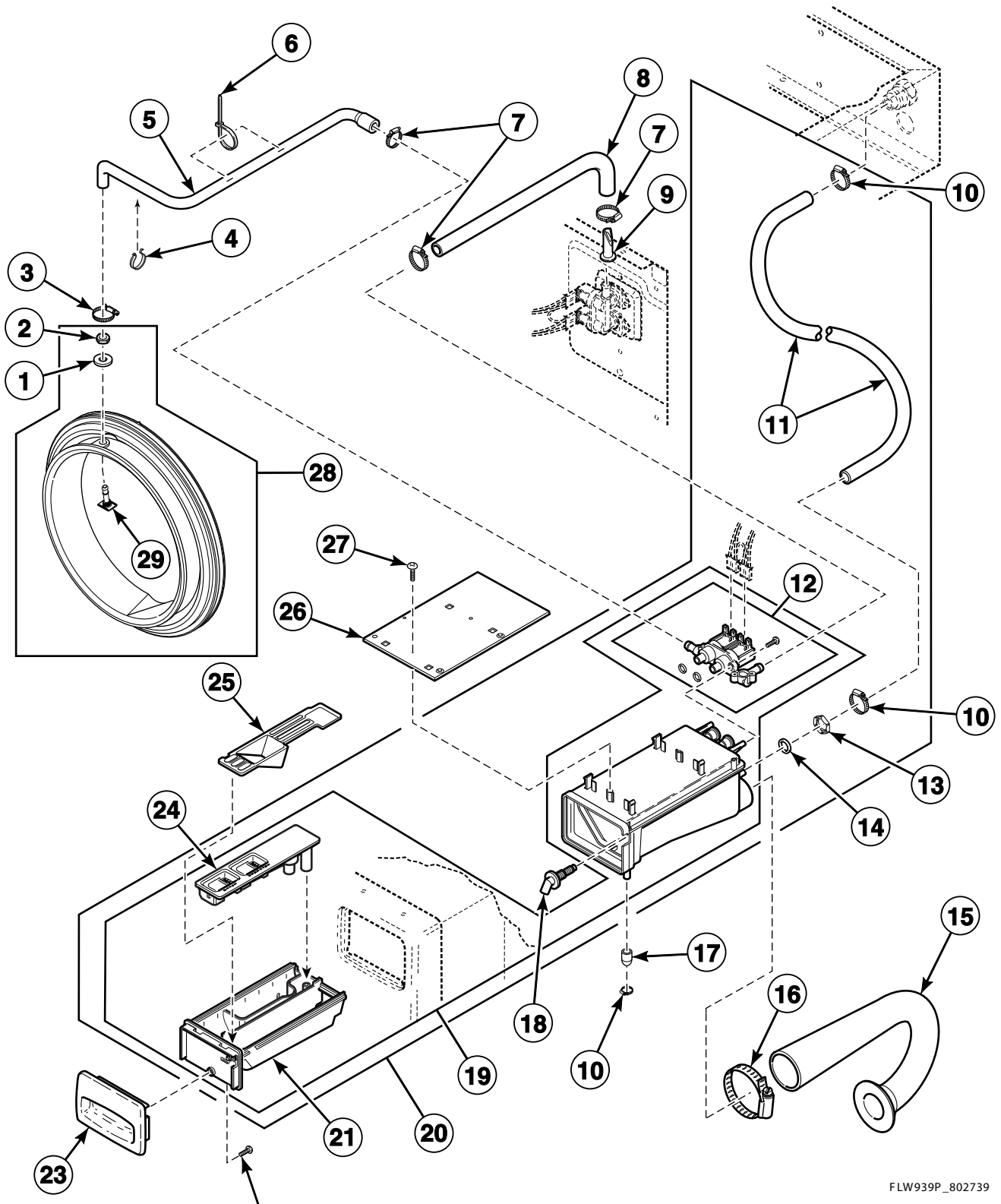

FLW939P_802739

SWF 3 P24

© Copyright, Alliance Laundry Systems LLC – DO NOT COPY or TRANSMIT

Dispenser Assembly

All Models Except SWFB72*N

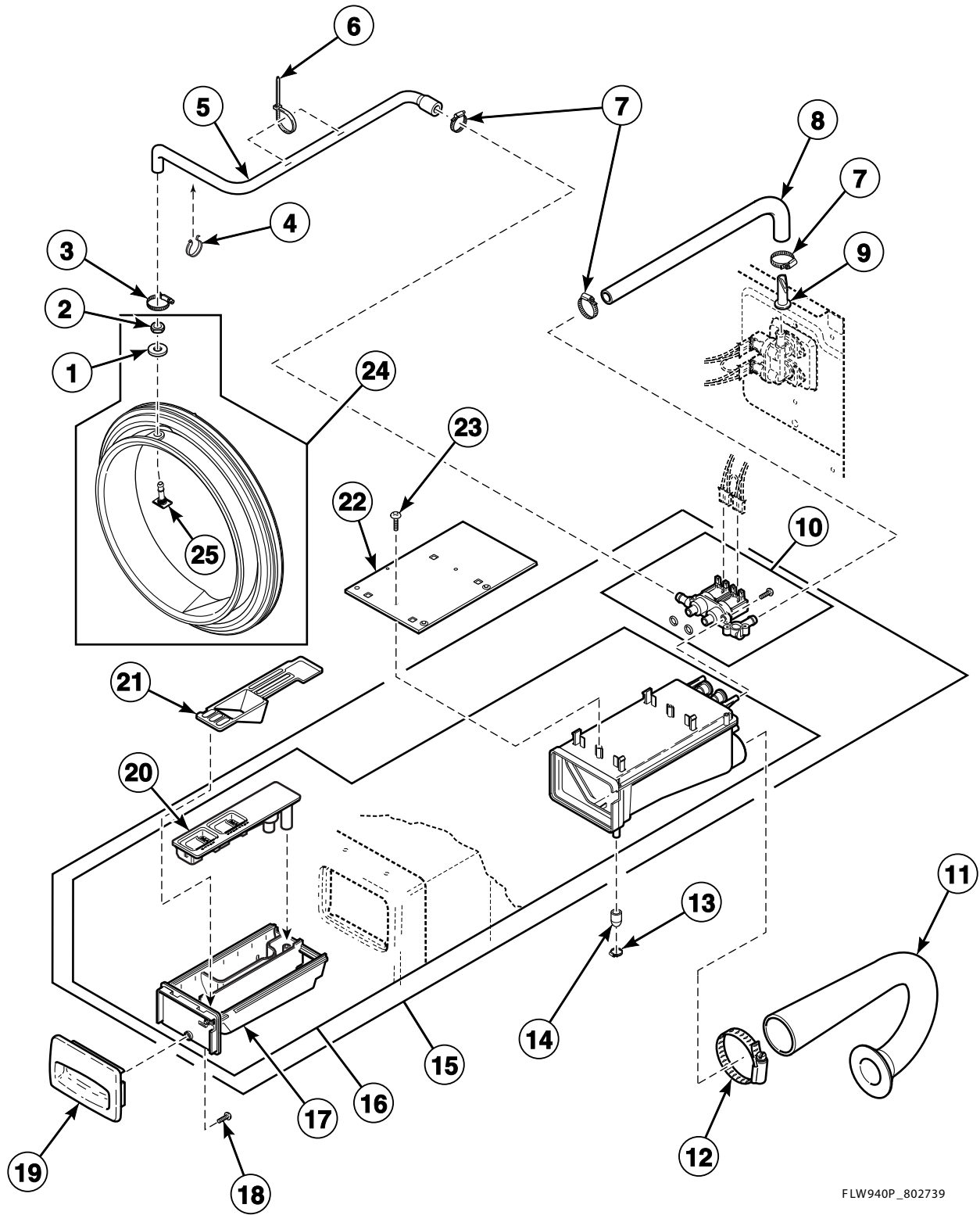

FLW940P_802739

SWF 3 P25

© Copyright, Alliance Laundry Systems LLC – DO NOT COPY or TRANSMIT

Mixing Valve, Inlet Hose and Dispenser Hose

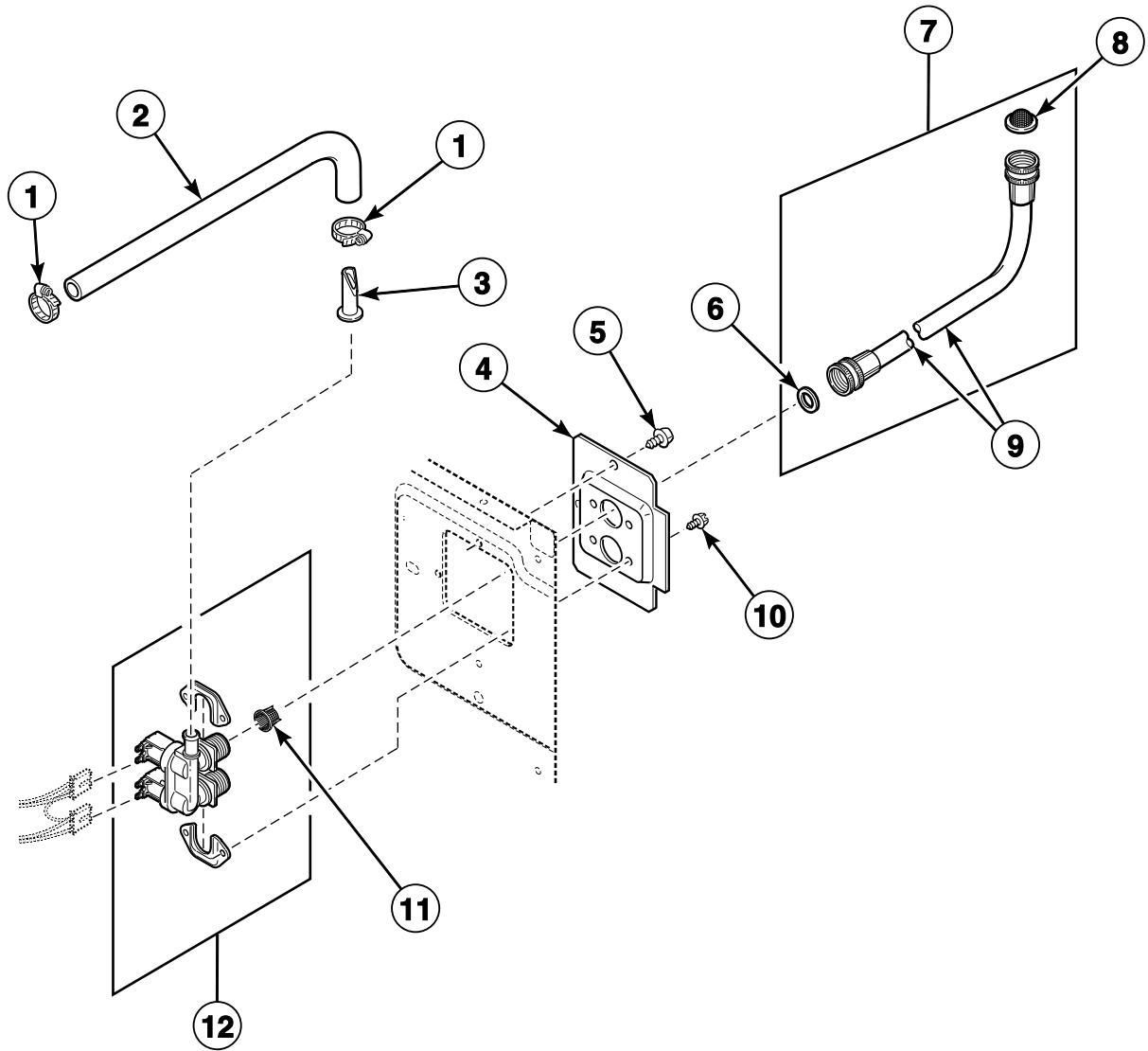

FLW881P_802739

SWF 3 P26

Outer Tub, Clamp Ring and Shock Absorbers

All Models Except BWFL74*N4000, BWFL75*N4000, BWFX74*N4000, BWFX75*N4000, HWFY74*N4000, HWFY75*N4000, NWFL84*N4000, NWFL85*N4000, NWFX74*N4000, NWFX75*N4000, SWFL74*N4000, SWFX74*N4000 and SWFX75*N4000

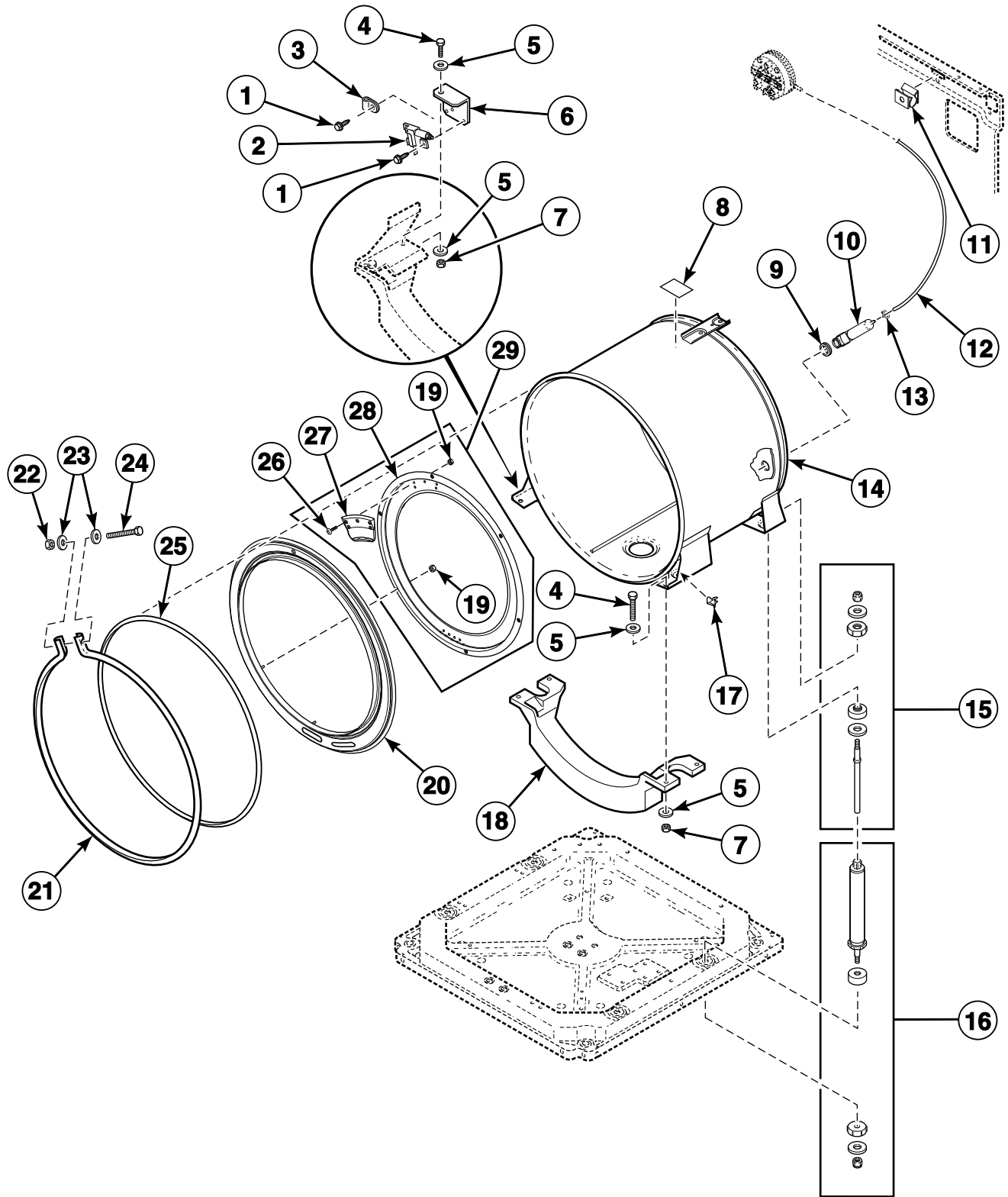

FLW1013P_802739

SWF 3 P27

Outer Tub, Clamp Ring, Shock Absorbers and Heating Element

Models BWFL74*N4000, BWFL75*N4000, BWF74*N4000, BWF75*N4000,
HWFY74*N4000, HWFY75*N4000, NWFL84*N4000, NWFL85*N4000, NWF74*N4000,
NWF75*N4000, SWFL74*N4000, SWFX74*N4000 and SWFX75*N4000

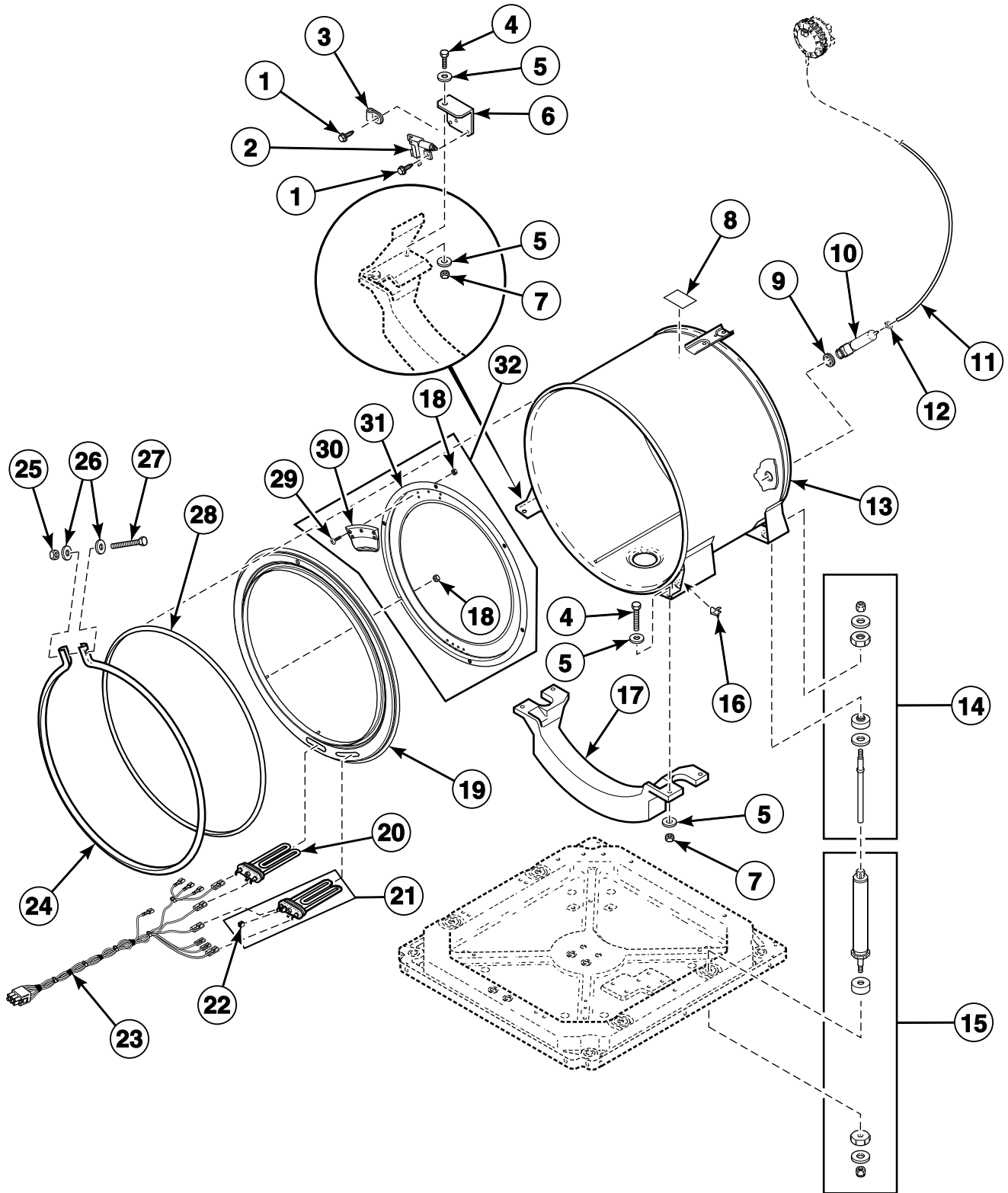

FLW1012P_802739

SWF 3 P28

Inner Basket, Trunnion, Bearing Housing and Pulley

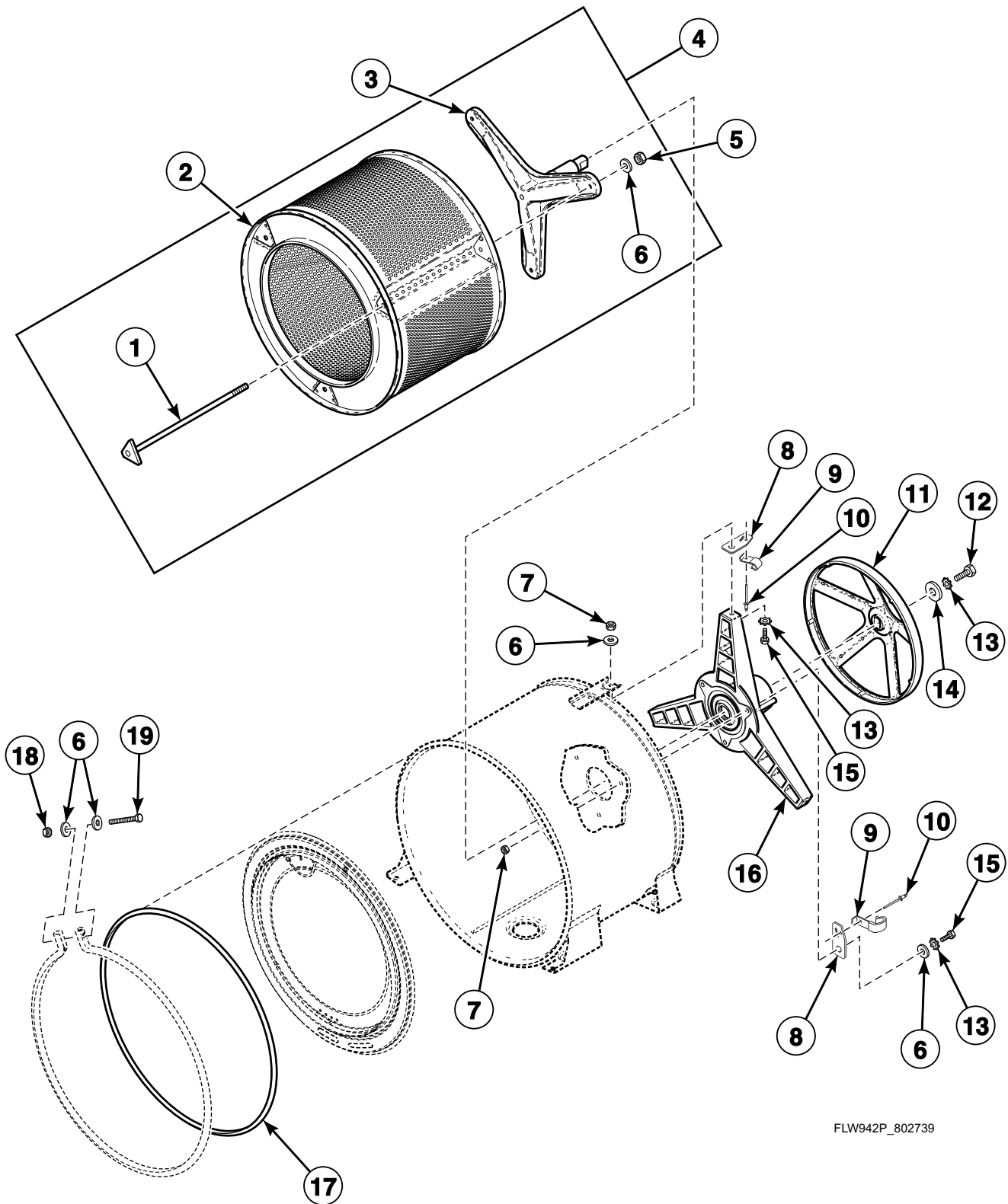

FLW942P_802739

SWF 3 P29

© Copyright, Alliance Laundry Systems LLC – DO NOT COPY or TRANSMIT

Motor and Belt

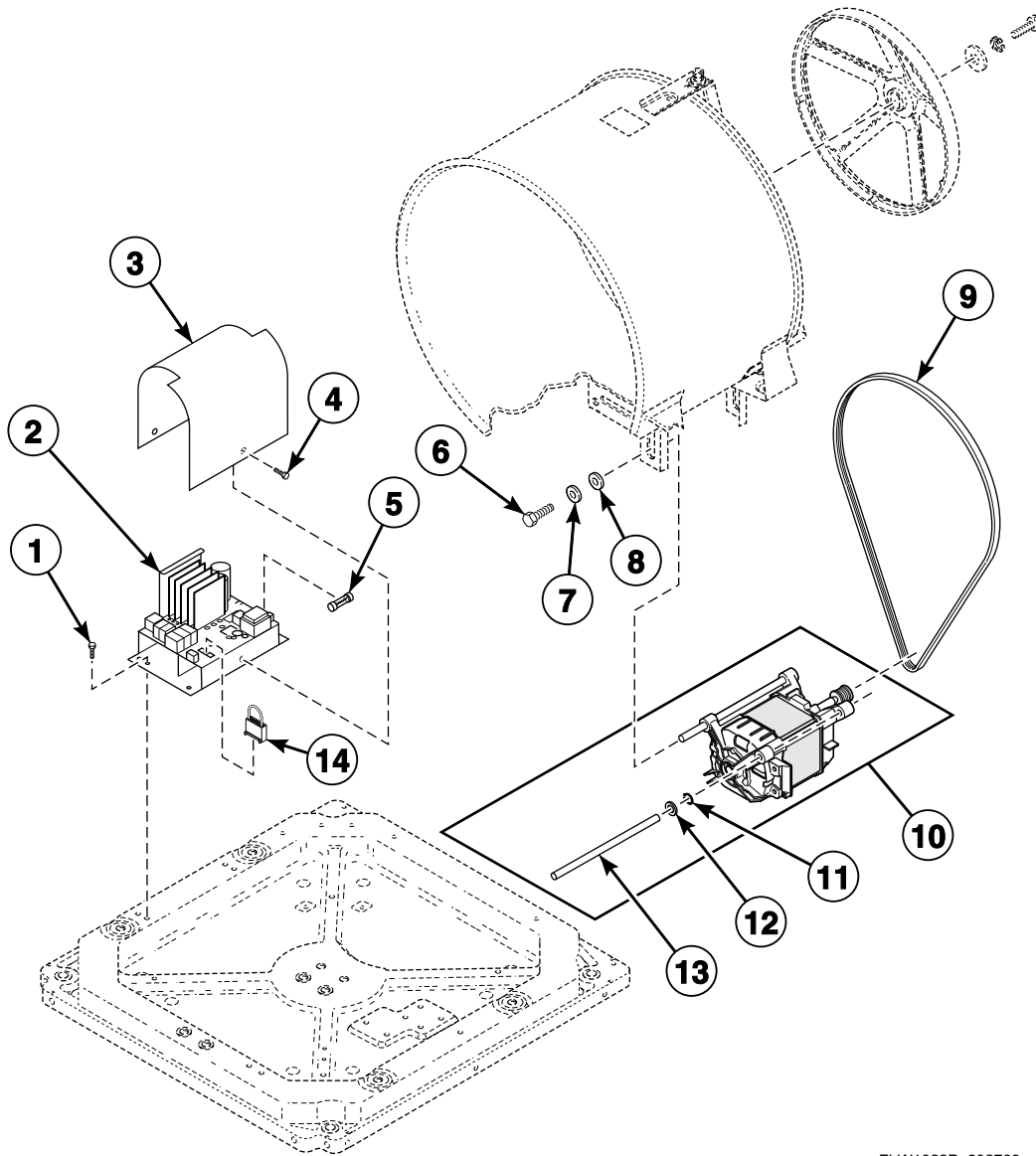

FLW1022P_802739

SWF 3 P30

© Copyright, Alliance Laundry Systems LLC – DO NOT COPY or TRANSMIT

Drain Hoses and Valve

Models BFNBCFSG111TN01, BFNBCFSG111TW01, BFNBCFSG112TN01, BFNBCFSG112TW01, BWFL75*N4000, BWFX75*N4000, HFNBCFSG111TN01, HFNBCFSG112TN01, HFNBCFSG112TQ01, HFNBCFSG112TW01, HFNBDFSG112CW01, HFNBDFSG112CW01, HWFT73*N, HWFT73*N1102, HWFY73*N1102, HWFY75*N4000, HWR973*N1102, NWFL85*N4000, NWFX75*N4000, SFNBCFSG112TQ01, SFNBCFSG112TW01, SFNBXFSG082JW01, SFNBXFSG112TQ01, SFNBXFSG112TW01, SFNBDFSG112TW01, SWFA73*N, SWFB73*N, SWFF73*N, SWFT73*N, SWFX73*N, SWFX75*N4000, SWFY73*N, SWR973*N and SWRT73*N

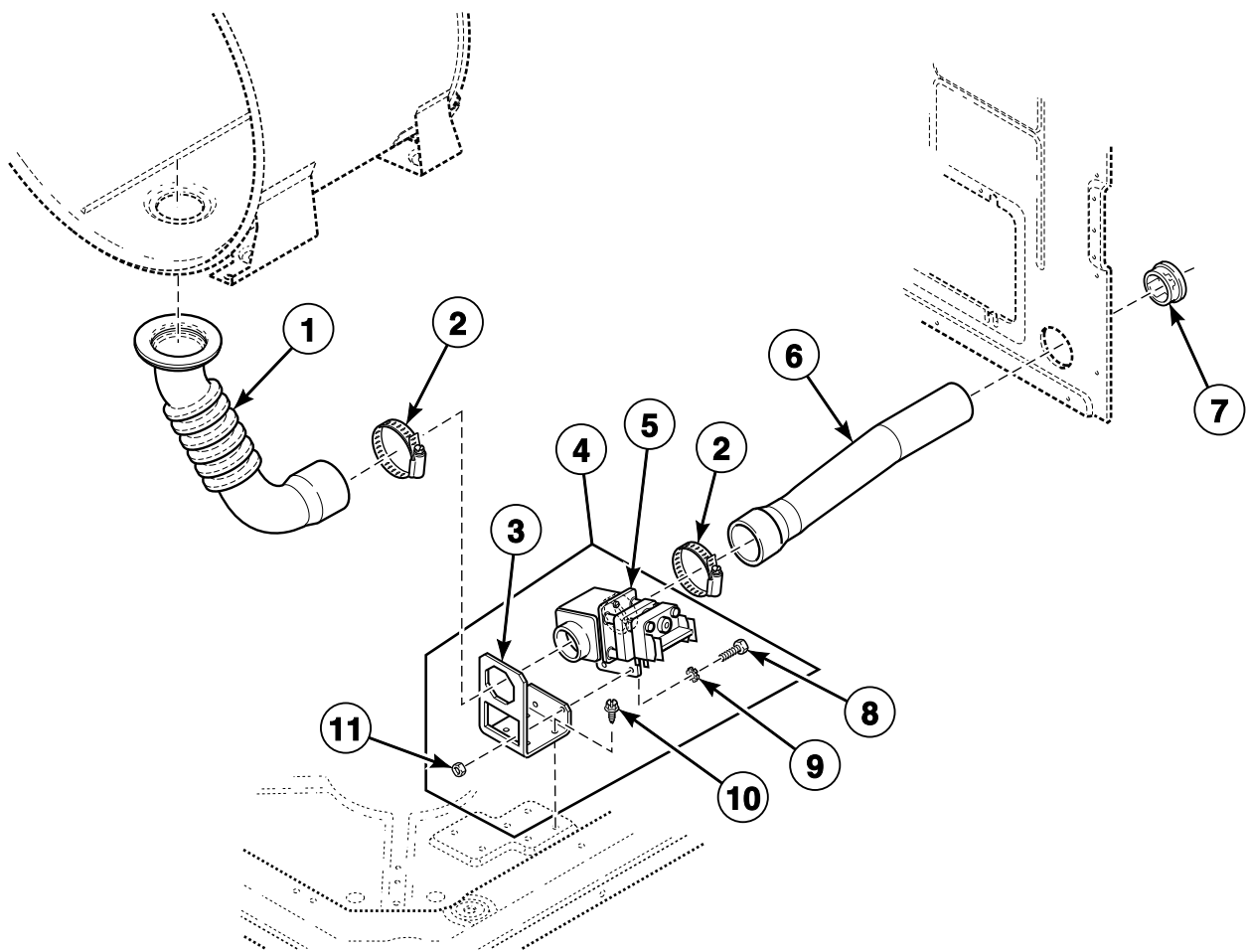

FLW888P_802739

Hoses and Pump

All Models Except BFNBCFSG111TN01, BFNBCFSG111TW01, BFNBCFSG112TN01, BFNBCFSG112TW01, BWFL75*N4000, BWFX75*N4000, HFNBCFSG111TN01, HFNBCFSG112TN01, HFNBCFSG112TQ01, HFNBCFSG112TW01, HFNBDFSG112CW01, HFNBDFSG112CW01, HWFT73*N, HWFT73*N1102, HWFY73*N1102, HWFY75*N4000, HWR973*N1102, NWFL85*N4000, NWFX75*N4000, SFNBCFSG112TQ01, SFNBCFSG112TW01, SFNBXFSG082JW01, SFNBXFSG112TQ01, SFNBXFSG112TW01, SFNBDFSG112TW01, SWFA73*N, SWFB73*N, SWFF73*N, SWFT73*N, SWFX73*N, SWFX75*N4000, SWFY73*N, SWR973*N and SWRT73*N

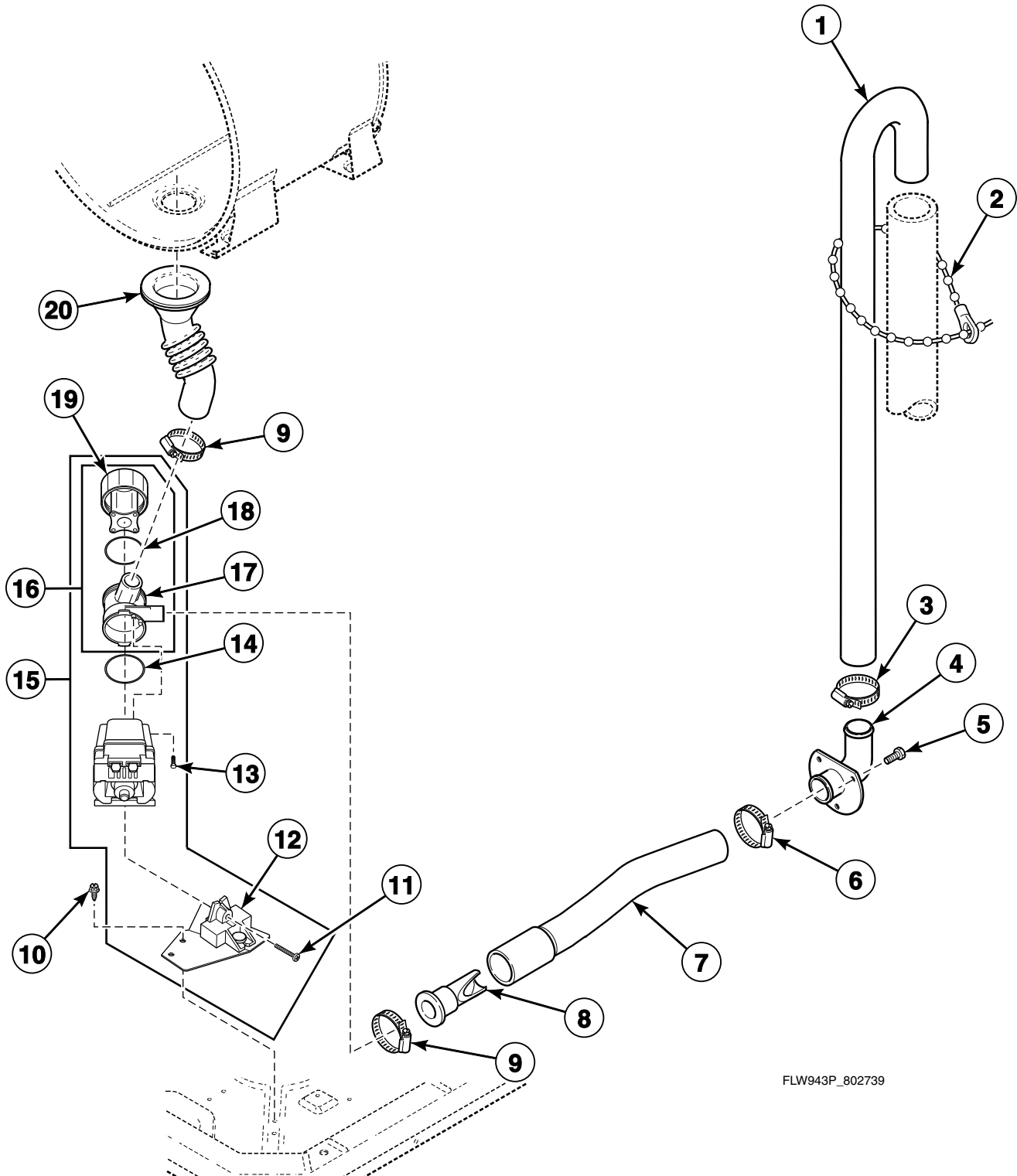

FLW943P_802739

Base, Side Panels and Rear Panel

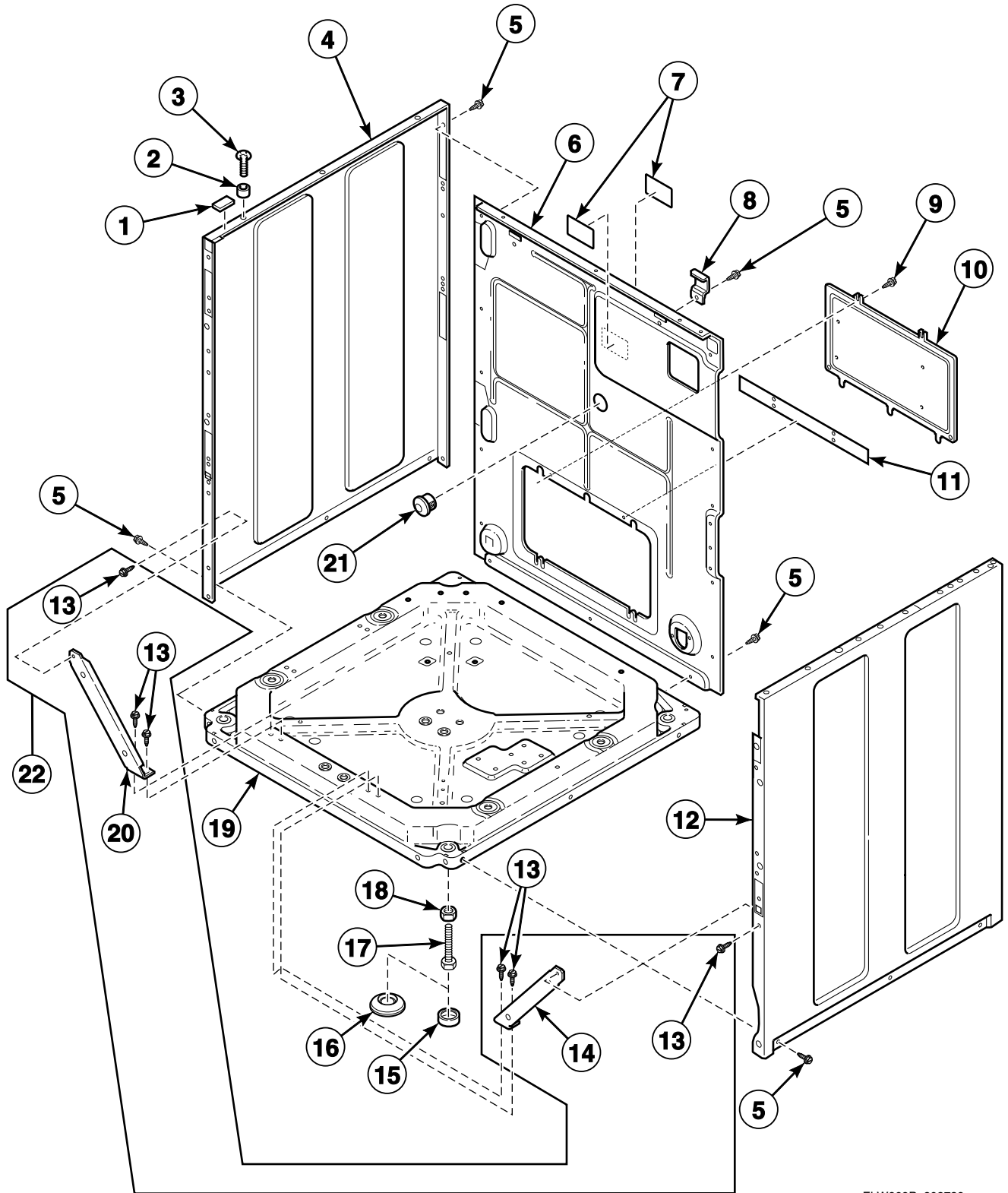

FLW969P_802739

SWF 3 P33

© Copyright, Alliance Laundry Systems LLC – DO NOT COPY or TRANSMIT

Junction Box

Model SWFB72*N

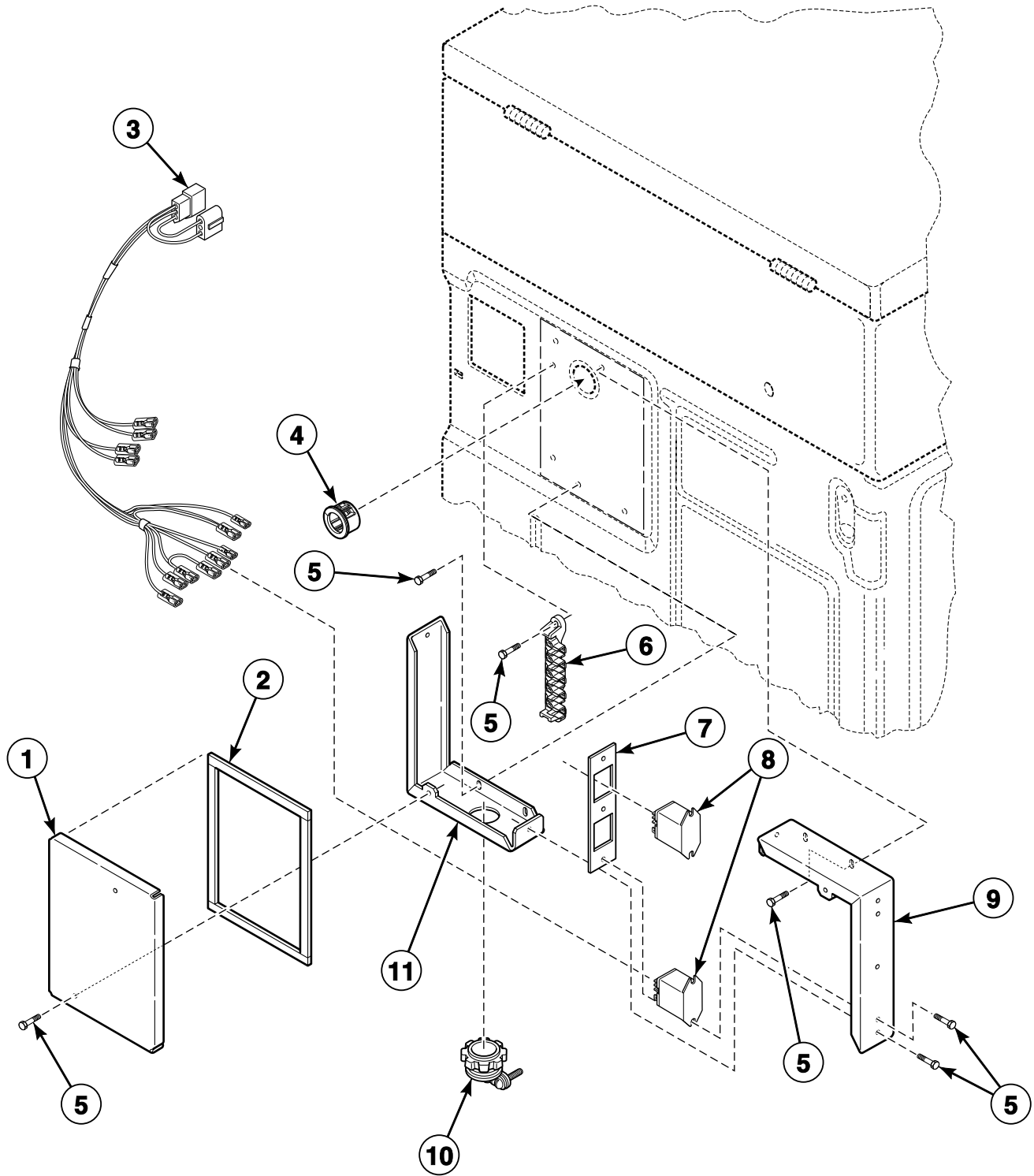

FLW903P_802739

SWF 3 P34

© Copyright, Alliance Laundry Systems LLC – DO NOT COPY or TRANSMIT

Junction Box and Power Cord

Models BFNBLFSP301AW01, BFNBLFSP302AW01, BFNBLFSP541NW01, BFNBLFSP542NW01, BFNBFSP112FW01, BFNBFSP302AW01, BWF71*N1127, BWF71*N3050, HFNBFSP112FQ01, HFNBFSP122DW01, HFNBFSP302NW22, HFNBFSP542DW01, HWF71*N1127, HWR971*N1127, SFNBFSG082JW01, SFNBFSP122DW01, SFNBFSP301NW22, SFNBFSP302AW01, SFNBFSP302NQ01, SFNBFSP302NW01, SFNBFSP302NW22, SFNBFSP542DW01, SFNSXRSP541NQ23, SFNSXRSP541NW23, SWFA71*N3050, SWFA71*N3069, SWFF71*N3050, SWFX71*N1127, SWFX71*N3000, SWFX71*N3050, SWFX71*N3051 and SWFX71*N5400

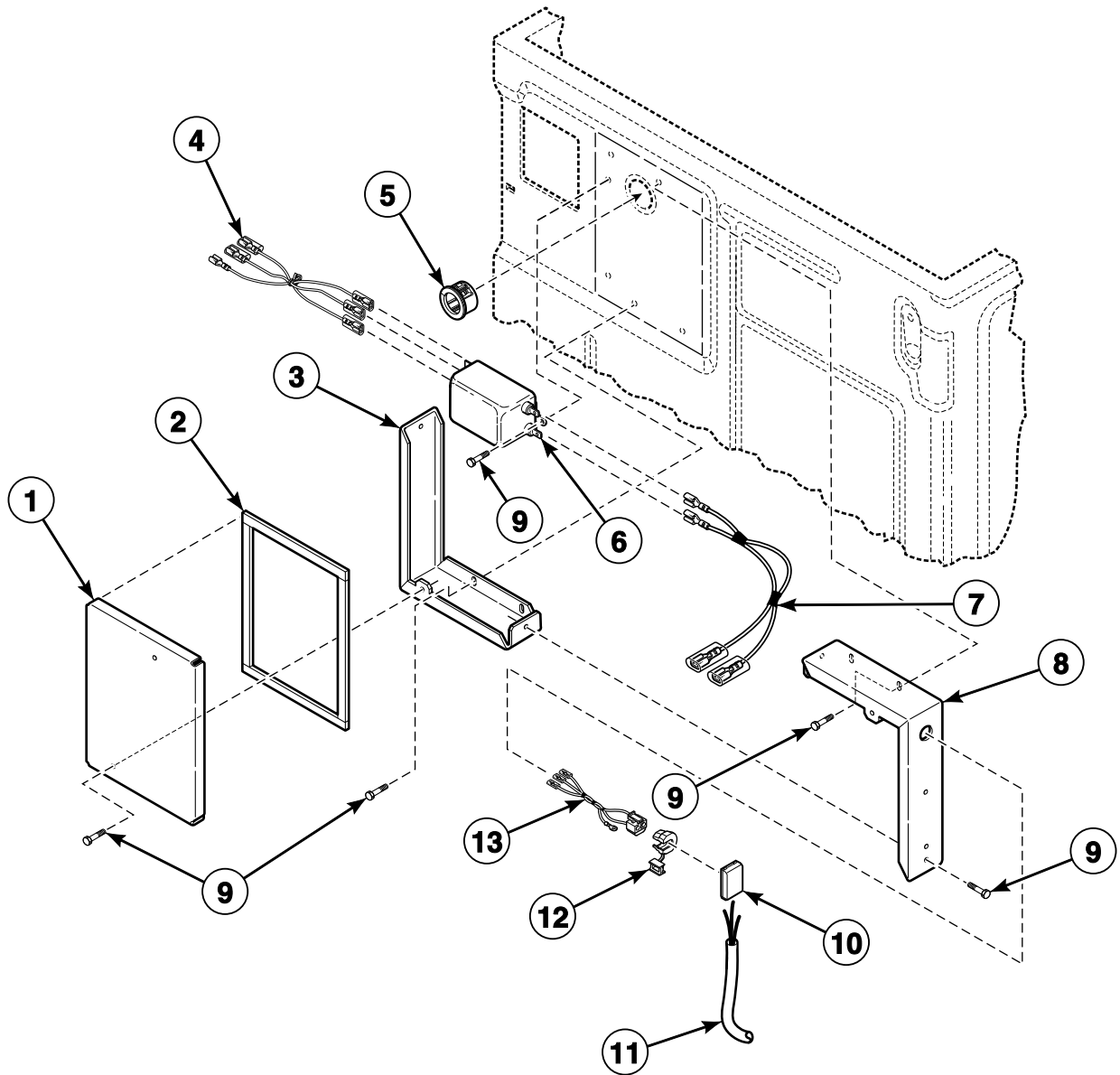

FLW1699P_802739

Shipping Materials

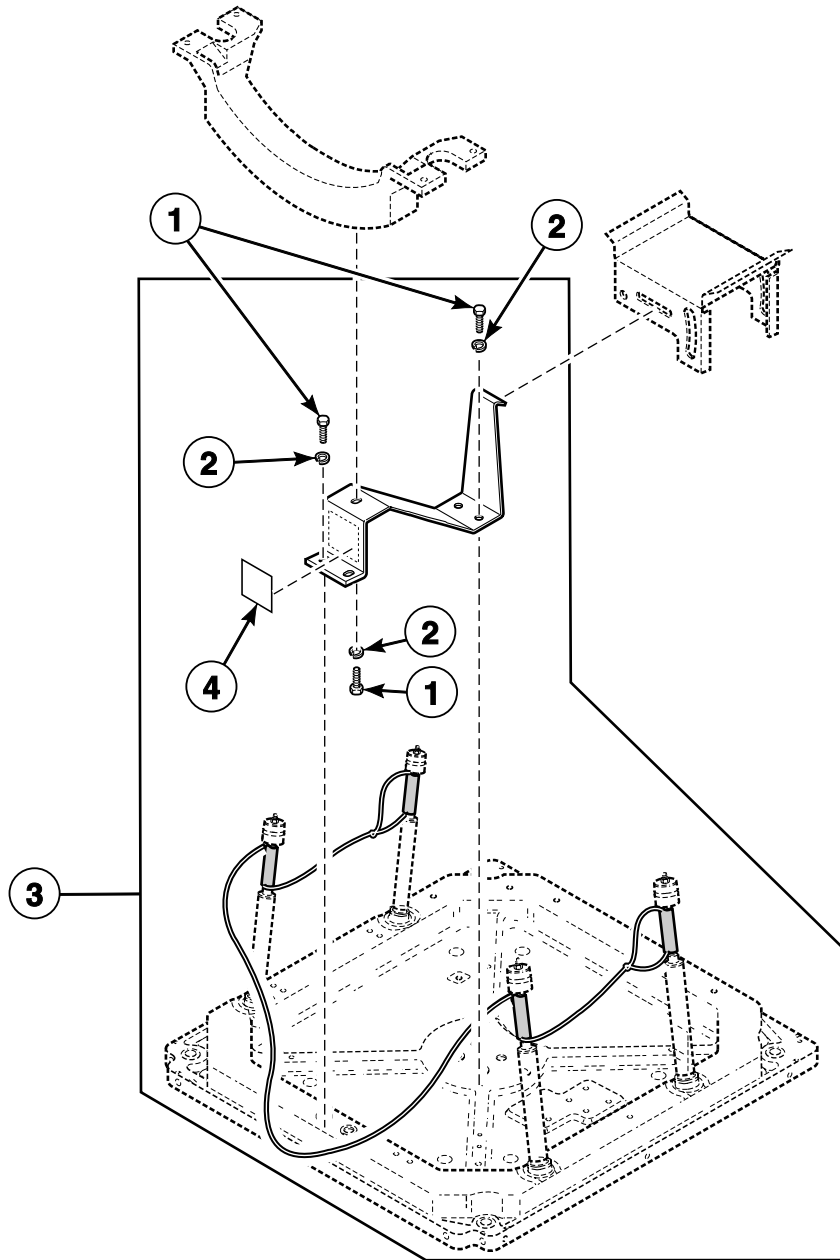

FLW1030P_802739

SWF 3 P36

© Copyright, Alliance Laundry Systems LLC – DO NOT COPY or TRANSMIT

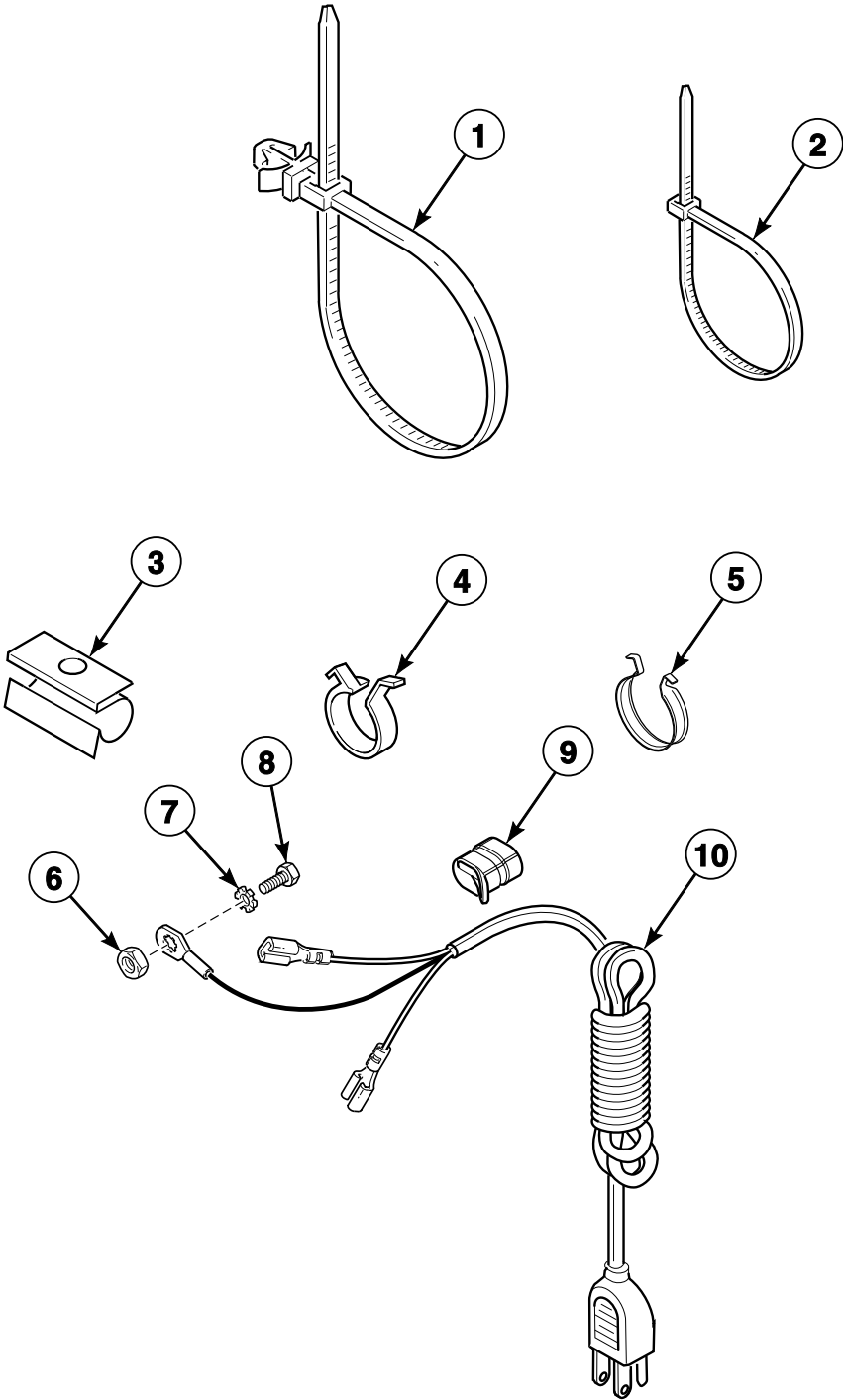

Special Tools

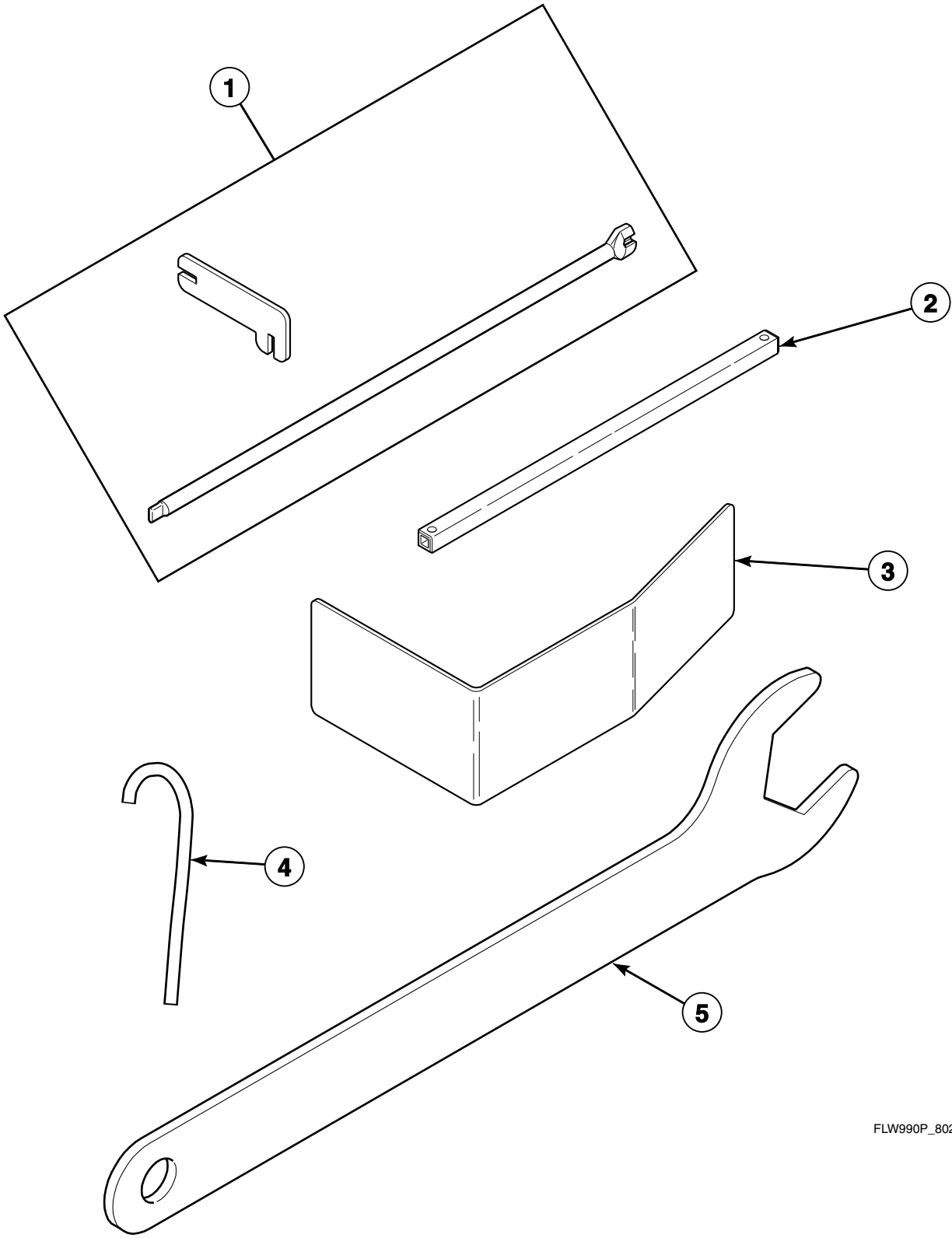

FLW990P_802739

SWF 3 P38

© Copyright, Alliance Laundry Systems LLC – DO NOT COPY or TRANSMIT

Labels

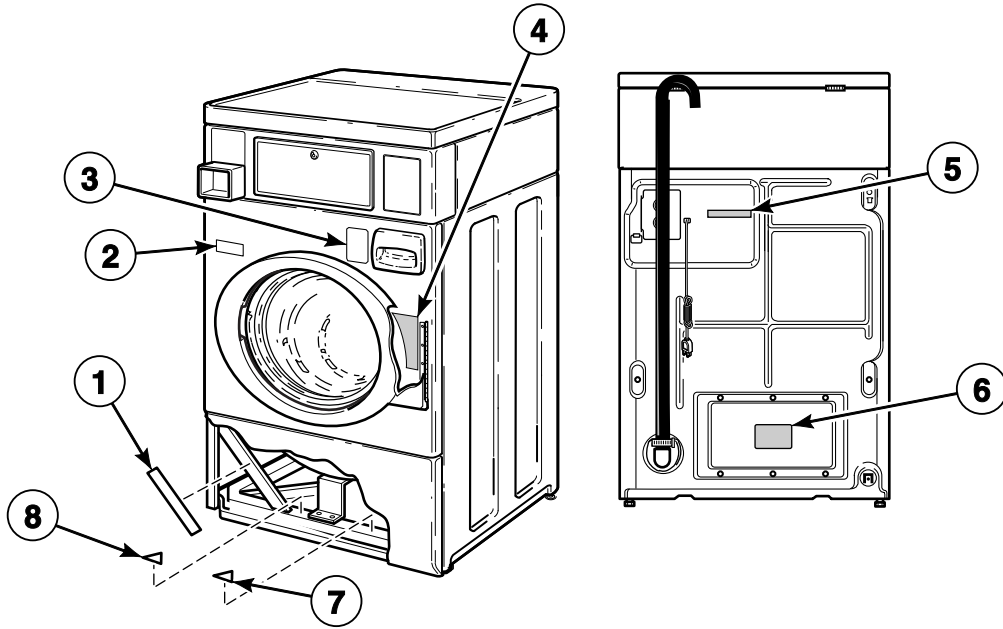

Front Control Washers

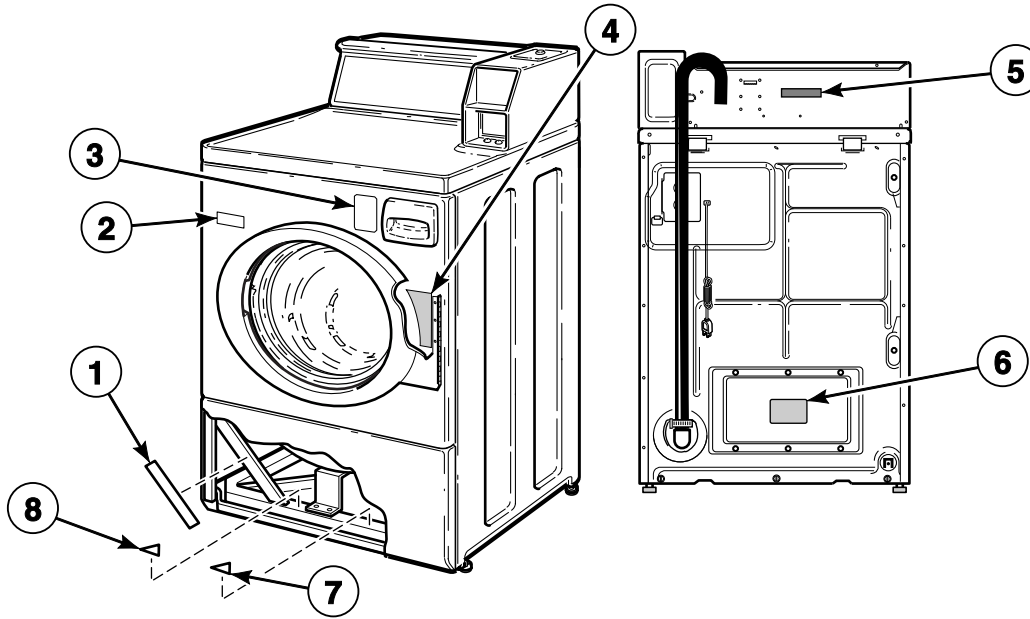

Rear Control Washers

FLW1031P_802739

Wire Harnesses and Wires (Drawing 1 of 2)

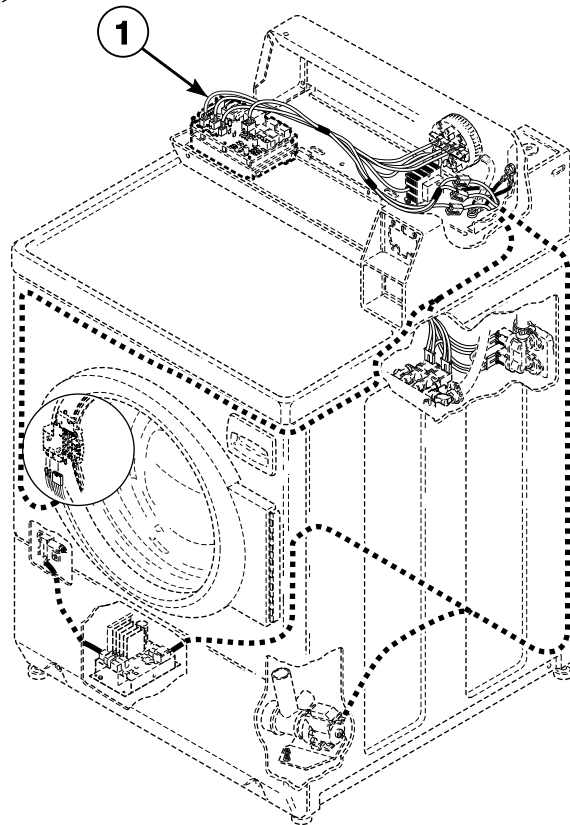
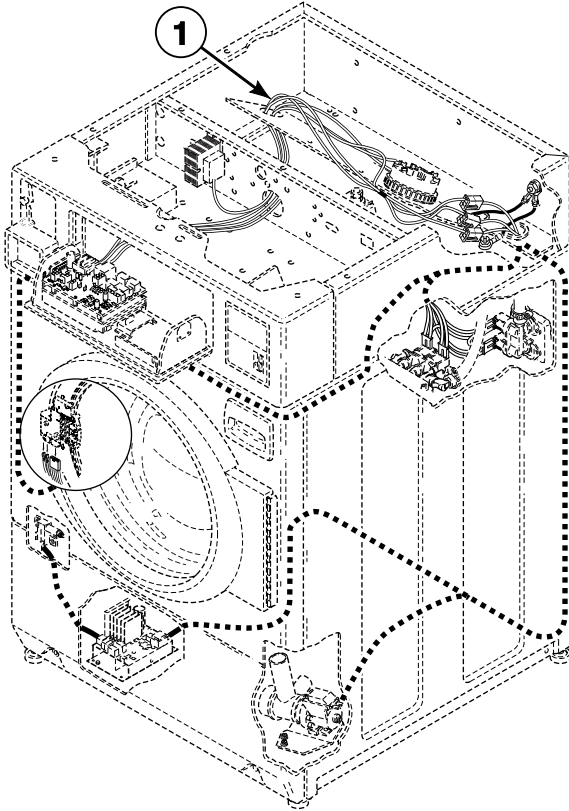

Wire Harnesses and Wires (Drawing 2 of 2)

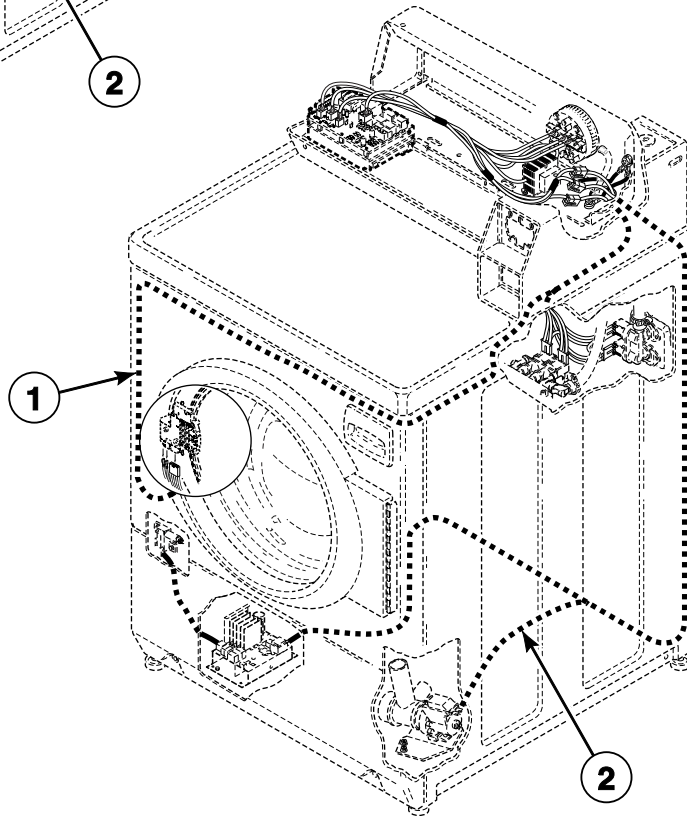
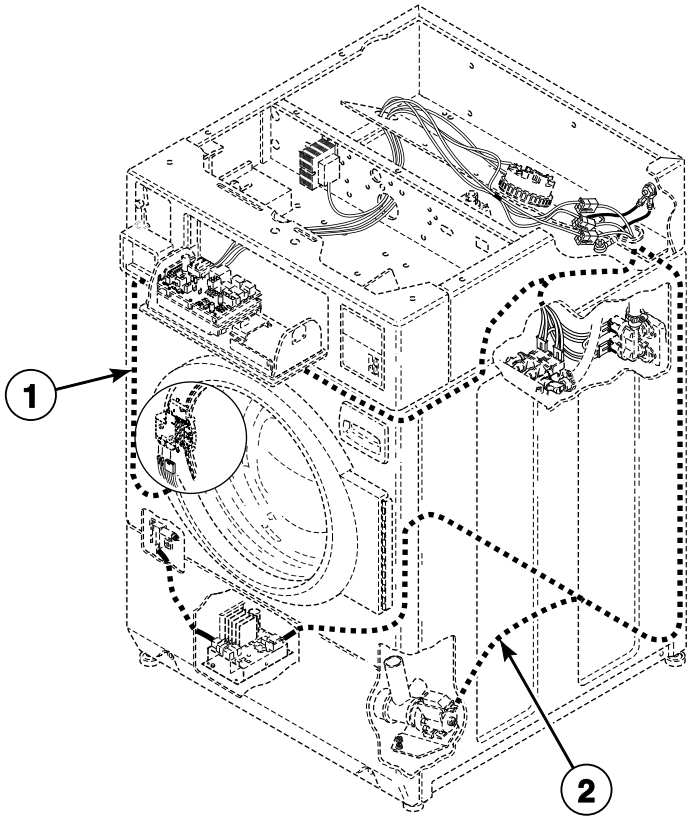

FLW945PA_802739

SWF 3 P41